



---

# The official New Zealand truck loading code



NZ TRANSPORT AGENCY  
WAKA KOTAHI

New Zealand Government

# The official New Zealand truck loading code

---

Code of practice for the safety of loads on heavy vehicles.

The *Truck loading code* sets out a code of practice for the safety of loads on heavy vehicles.

It has been prepared to provide owners, drivers, operators and loading staff with guidance in the basic safety principles that must be followed generally, and in particular the precautions that must be taken to ensure the safe carriage of a number of the more common types of load, including containers, pallets, construction equipment, logs and sawn timber.

This edition published 2012 by the NZTA,  
Private Bag 6995,  
Wellington 6141.

First published in 1985.  
©NZ Transport Agency

All rights reserved. No part of this publication may be reproduced by any means, electronic, mechanical, electrostatic photocopying or otherwise, or stored in a retrieval system without the prior permission of the NZTA.

ISBN 978-0-478-38012-5

## Acknowledgments

---

Acknowledgment is made of the permission given by the Department of Transport, Australia, to make use of material contained in the Truck loading code: Recommended code of practice for the safety of loads on road vehicles, printed in Australia in 1981; and for permission given by the Department of Labour to duplicate the majority of information contained in their Approved codes of practice: Timber stacking, packaging and transportation, issued July 1994 and Safety and health in forest operations, 1999.

## Legislation

---

The Land Transport Act 1998 contains the load security legislation that is administered by the NZTA and enforced by the NZ Police. It provides strict liability for offences involving insecure loads and loads falling from vehicles. Offences attract fines for an individual of up to \$2000 and a licence may be disqualified for a period as the Court thinks fit. The maximum fine for a body corporate is \$10,000.

In any proceedings for an offence the Court must, in determining whether or not the operator or any person loading the vehicle was at fault, have regard to this code of practice. This code details the general requirements that must be met to ensure a load cannot fall. The defendant must be able to show that the load restraint system was capable of preventing movement of the load under all four of the following conditions:

1. During deceleration in the forward direction, when the restraining forces must be at least equal to the weight of the load, ie an acceleration of 1.0g.
2. During deceleration in the rearward direction, when the restraining forces must be at least half the weight of the load, ie an acceleration of 0.5g.
3. During cornering when the load is subjected to lateral or sideways acceleration, when the restraining forces must be at least half the weight of the load, ie an acceleration of 0.5g.
4. While travelling over undulating roads, bumps and potholes, etc, the vertical restraining forces holding the load down must be at least one-fifth of the weight of the load, ie an acceleration of 0.2g.

The above requirements are detailed on pages 8-17, and information is provided on how to comply.

This code details the minimum acceptable methods of securing specialised loads to ensure they meet the four conditions above. Other load securing methods are acceptable provided the conditions stipulated above are met.

# Contents

<b>General requirements</b>	<b>5</b>
Introduction	5
The safety problem	7
Basic criteria and precautions	8
Strength requirements of restraint systems	14
Load-securing equipment	18
<b>Specialised requirements</b>	<b>26</b>
Containers	26
Pallets	32
General freight	35
Construction equipment	47
Timber loads	60
Steel products	78
Loose bulk loads	87
Pipe loads	88
Reels	93
Carriage and towing of motor vehicles	98
Flexible tanks	101
Dangerous goods	105
Live loads	105
<b>Appendices</b>	<b>106</b>
Appendix A	106
Appendix B	110
Appendix C	116
<b>Index</b>	<b>118</b>



# General requirements

## Introduction

The correct loading of heavy vehicles is vital in the prevention of injury to drivers and members of the public and the prevention of damage to materials and equipment.

Vehicle loads must be sufficiently restrained to prevent movement from the forces arising from the vehicle passing over road undulations, changing direction or when it is being braked or accelerated. It requires much more force to stop a load that has started moving than it does to prevent the movement in the first place. It is essential that the load is restrained to prevent movement in any direction relative to the vehicle. Friction between the load and the vehicle platform cannot be relied on to make a load secure. Dynamic forces will tend to exceed such frictional forces and render a load insecure. It is therefore necessary to provide additional restraint to prevent the load moving. This restraint is normally provided by means of lashings secured to the vehicle chassis and load platform or by various baulking arrangements such as loading racks, headboards and chocks.

This code of practice for the safe loading of heavy vehicles has been prepared to provide owners, drivers, operators and loading staff with guidance in the basic safety principles that must be followed generally, and in particular the precautions that must be taken to ensure the safe carriage of a number of the more common types of load. Other methods of securing loads are acceptable, providing a certifying engineer has certified the system. Tests may also have to be conducted to confirm that the security of the load meets the criteria specified (see pages 8-13).

The code provides a range of valuable information based on proven good practices in this field and has been influenced particularly by the increasingly higher performance capabilities of modern vehicles.

## Do

- make sure your vehicle's load space and the condition of its load platform are suitable for the type and size of the load
- make use of adequate load anchorage points
- make sure you have enough lashings and that they are in good condition and strong enough to secure your load
- tighten up the lashings or other restraining devices
- make sure that the front of the load is abutted against the front rack or headboard, or other fixed restraint
- use wedges and chocks so that your load cannot move
- make sure that loose bulk loads cannot fall or be blown off your vehicle.

## Don't

- overload your vehicle or its individual axles
- load your vehicle too high
- use rope hooks to restrain heavy loads
- forget that the size, nature and position of your load will affect the handling of your vehicle
- forget to check your load:
  - before moving off
  - after you have travelled 25km and periodically thereafter, such as at tyre checks
  - every time you remove or add items to your load during your journey
  - after emergency braking or an excessively sharp or violent manoeuvre
- take risks
- move the vehicle if any part of the load is not secured
- leave loose wedges, lashings, chock and dunnage, etc lying on the vehicle deck once the load has been removed.

# The safety problem

Any load carried on a vehicle must be sufficiently restrained to prevent movement caused by the forces that arise from the vehicle passing over road undulations, when it changes direction or when it is being braked or accelerated (see figures 1 and 2).

The forces involved in restraining the load when braking depend on the deceleration and the weight of the load. Thus, as braking efficiencies and vehicle payloads increase, it becomes more important that load restraint should be adequate.

The forces involved in restraining a load under braking are not dependent on the speed of the vehicle. They may be the same at low speeds as at high speeds, in both forward and reverse directions. If, however, a load does move at high speed, it will have more energy and will cause more damage.

It requires much more force to stop a load that has started moving than it does to prevent the movement in the first place. It is essential that the vehicle is loaded and the load restrained in such a way that no part of the load can freely move in any direction relative to the vehicle.

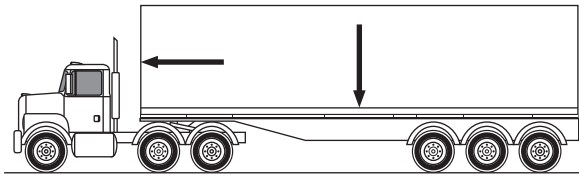


Figure 1

The total restraint required to accommodate the forces that arise will generally be obtained from a combination of the following:

- Lashings secured to the vehicle's anchor points.
- Baulking arrangements, including load racks, headboards, stakes in pockets, transverse beams, shoring bars, chocks and dunnage, etc.
- Friction between the load and the vehicle platform.

A load carried on a vehicle without restraining devices will not be secure because the frictional restraint between the load and the platform of the vehicle will be less than the dynamic forces that tend to move the load. It follows, therefore, that it is necessary to provide additional restraint to prevent the load moving.



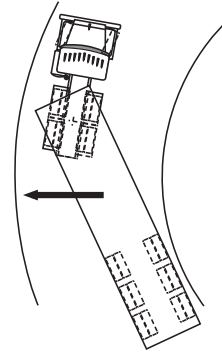


Figure 2

## Basic criteria and precautions

### METHODS OF LOAD RESTRAINT

The basic concept of load restraint systems outlined in this code of practice is that they should prevent movement of the load under the following conditions:

- During deceleration in the forward direction, when the restraining forces must be at least equal to the weight of the load (ie an acceleration of 1.0g).
- During deceleration in the rearward direction, when the restraining forces must be at least half the weight of the load (ie an acceleration of 0.5g).
- During cornering when the load is subjected to lateral or sideways acceleration. The restraining forces must be at least half the weight of the load (ie an acceleration of 0.5g).
- While travelling over undulating roads, bumps and potholes, etc. The vertical restraining forces holding the load down must be at least one-fifth of the weight of the load (ie an acceleration of 0.2g).

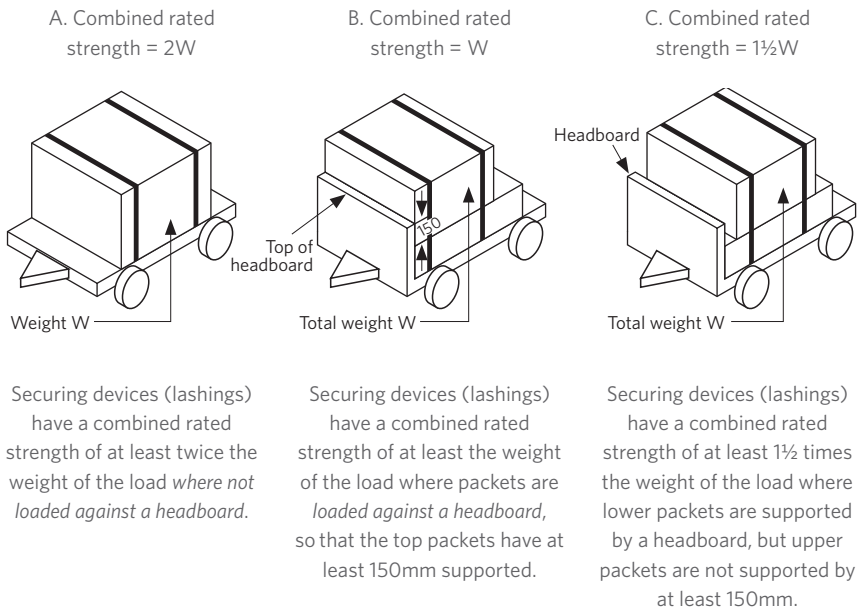
### *Securing rigid loads weighing 0.5 tonne or more*

The following are ways in which the above criteria are met when securing rigid loads (whole bound packets, boxes or crates, etc):

- Packets that are to be transported on a vehicle platform must be secured by securing devices that pass from the deck on one side of the vehicle over the load to the anchor point on the other side of the deck.
- Packets that are not loaded against a headboard, the securing devices must have a combined rated strength of at least twice the weight secured, eg a 10-tonne payload will require two chains, each having a rated strength of 10 tonnes.

- Packets that are loaded against a headboard so that the top packets are supported by at least 150mm. The securing devices must have a combined rated strength of at least the weight secured, eg a 10-tonne payload will require two chains, each having a rated strength of 5 tonnes.
- Packets that are loaded so that the lower packets are supported by a headboard but the upper packets are not supported must be secured by securing devices having a combined rated strength of at least 1.5 times the weight secured, eg a 10-tonne payload will require two chains, each having a rated strength of 7.5 tonnes.
- Products that are not bound together in packets (eg loose timber) must be transported as if they were packaged. However, suitable centre or side posts and side gates must also be used.

The above is based on the *Safety code for timber stacking, packaging and transportation*.



**Figure 3** Rated strength of vertical securing devices for rigid loads on heavy motor vehicles

## ***Rated strength***

For chains and steel wire ropes, the rated strength must be equivalent to not more than the specified minimum breaking force. For webbings and other ropes, the rated (assembly) strength must be equivalent to not more than half the breaking strength. In order that the restraining system is at all times fully effective, it is essential that certain basic requirements are met.

These are outlined below:

### **SUITABILITY OF VEHICLE**

In addition to meeting the statutory requirements applicable to the construction, equipment and loading of motor vehicles, the vehicle's load space and the condition of the platform must be suitable for the type and size of the load to be carried.

### **FRICTION**

A slippery platform surface is always dangerous. The aim should be to obtain the maximum advantage from the frictional restraint by keeping both the base of the load and the platform surface as clean, dry and free from grease as possible. Special precautions should be taken to secure loads when metal-to-metal contact cannot be avoided.

### **DUNNAGE**

The use of loose dunnage between the load and the platform should be avoided wherever possible. However, where dunnage must be used because of the shape of the load and the need to provide adequate support, this should be selected and secured so as to prevent movement during the journey. Timber dunnage should be of uniform thickness and of the maximum possible width. The minimum width should, where practicable, be twice the thickness. A single layer is preferred to a double layer between the base of the load and the body deck and also between layers of load, if any.

### **BAULKING**

The front of the load should be abutted against the headboard, front rack, or an obstacle fitted transversely across the vehicle platform and firmly attached to the chassis frame. Blocks, wedges and chocks may be used to prevent individual items of a load from moving in any horizontal direction. Care must be taken to ensure that these are strong enough and are adequately secured to the vehicle platform.

### **LOAD ANCHORAGE POINTS**

The number of anchorage points fitted and used and their strength should be based on the principles outlined on pages 14–17. In the case of those existing vehicles where the provision of such anchorage points is impracticable, adequate

load restraint must be achieved by other available means, including baulking. Anchor points that are secured to wooden members only are not likely to be strong enough to provide the restraint required and should be designed to transmit the restraint forces to the vehicle chassis.

## **LASHINGS**

The lashings or fastening devices, twitches and chains, cables, clamps, load binders, etc should be in a sound condition and must be capable of transmitting all the forces likely to be induced in them. The following requirements should be met:

- The lashings or fastening devices must be properly tensioned at all times. They must be periodically checked during the journey to avoid the load moving on the vehicle platform, and to keep it firmly against the headboard or other obstacle referred to in the paragraph on baulking above. Overtensioning should be avoided as this can overload the lashings or fastening device and weaken it.
- The restraining system should be arranged so that the failure or slackening of a single component does not render the remainder of the system ineffective.
- Lashings must not contact any sharp edges on the vehicle or load.

## **TARPAULINS**

Except in the case of very light bulk loads (0.5 tonne or less), sheets or tarpaulins should be regarded as providing no more than weather protection, and the load must be independently restrained against movement.

## **SECURITY**

The load securing system should be arranged so that it cannot be accidentally released by vibration or movement of the load while the vehicle is in motion.

## **ALL ITEMS OF EQUIPMENT**

Dunnage, chocks, etc must be securely restrained when not in use wherever they are placed.

## **LOAD DISTRIBUTION AND ARRANGEMENT ON VEHICLES**

The first priority with any load is to keep within the maximum legal weight limits and vehicle dimensions. The load should be placed against the headboard, provided the handling of the vehicle is not impaired. If the load cannot be placed against the headboard, baulking as described earlier should be used, or twice the strength of lashings are required.

The load should be spread to keep the centre of gravity as low as possible. Where the load is stacked, larger and heavier items should be placed at the bottom (see figure 4).

The vehicle should be loaded to give correct axle distribution and an even weight distribution over its floor area (see figure 5). In order to maintain lateral stability, the centre of gravity of the load should be on, or as near as possible to, the centre line of the vehicle.

It is better for heavier items to be carried on the centre line of the vehicle than at the sides.

Heavy solid items should, where possible, be placed in front of light crushable ones or be restrained.

Part loads of heavy solid items should, where possible, be placed over the region of the axles. Do not exceed maximum permitted axle weights.

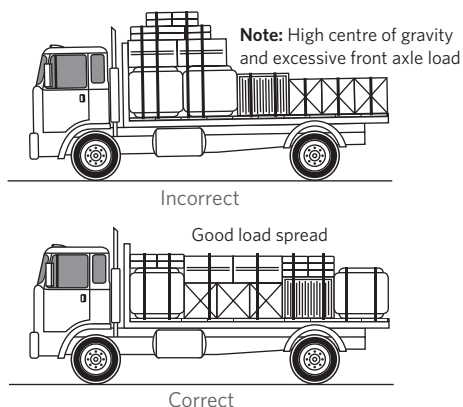


Figure 4

The load should be placed against the loading rack of the loading platform, or wedged against the rack as prescribed below. As far as possible, the load should be redistributed after each partial unloading to maintain the overall balance, ensuring maintenance of drive traction and steerability. The load should not be leant against a rack not designed for that purpose. The weight of heavy loads of small dimensions should be distributed on side members, a platform or a bearer cradle.

A high load will seriously affect the stability of the vehicle and may cause it to overturn when cornering. It is imperative, therefore, that this type of load is carried on vehicles with a low platform whenever possible. Generally, the height of the load must not exceed the length of the load, and twice the width of the load.

A load must not exceed 3 metres ahead of the front of the driver's seat or more than the regulations allow behind the rear axis. If it extends more than 1 metre ahead or behind the body of the vehicle, it must have a clean white flag or a red, orange or yellow fluorescent flag attached to the end of the load. It must be at least 400mm × 300mm.

Loads incorporating any dangerous projection should be arranged to minimise risk to the driver and other road users. If progressive unloading occurs, it is essential to resecure the load.

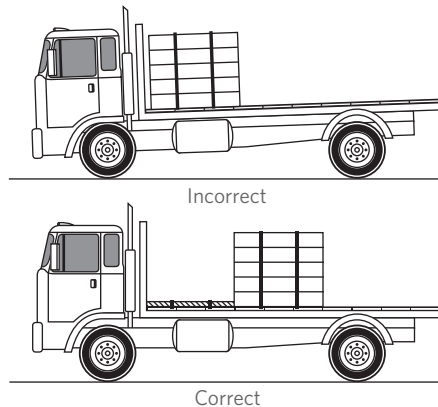


Figure 5

## LOAD HEIGHT

A person mustn't operate any vehicle if the vehicle and/or its load rise to a height that is liable to cause damage to any construction or wires lawfully over the roadway. A vehicle cannot exceed the height of 4.25 metres from the ground, unless a permit has been obtained from the Overdimension Permit Issuing Agency (OPIA).

# Strength requirements of restraint systems

It has been stated that the load restraint system must be capable of preventing movement of the load under four particular conditions:

- 1 Forward deceleration under emergency braking conditions when the combined restraining forces must be at least equal to the payload weight, ie an acceleration of 1.0g.
- 2 Rearward deceleration when braking during reversing when the combined restraining forces must be at least 50 percent of the payload weight, ie 0.5g.
- 3 Sideways or lateral acceleration when cornering when the combined restraining forces must be at least 50 percent of the payload weight, ie 0.5g.
- 4 Vertical acceleration when travelling over undulating roads, bumps and potholes, etc when the vertical restraining forces holding the payload down must be at least one-fifth of the payload weight, ie 0.2g.

## FORCES INVOLVED

The forces resulting from these deceleration and acceleration factors, which must be safely contained by the load restraint system, are greatly increased if the load is allowed to move relative to the vehicle, ie the 'battering ram' effect. The restraint system must be designed, constructed and used in such a way as to prevent this.

The ram effect increases rapidly with the increase in distance through which the load may be free to move relative to the vehicle. It is hazardous to locate loads away from the headboard or other fixed abutment unless the means used for load restraint are adequate to prevent such movement under the conditions described above. Failure of the load restraint system in these circumstances could result in the load developing sufficient momentum, if allowed to slide, to demolish the headboard or other abutment with potentially serious consequences.

## LOAD RESTRAINT

As indicated on page 7, the forces involved in restraining a load from movement will normally be provided by:

- lashings secured to anchor points
- baulking arrangements, including headboards, pockets and stakes, traverse beams, shoring bars, chocks and dunnage, which are securely attached to the vehicle
- friction between the load and the vehicle platform.

In most circumstances, it will be appropriate to obtain half the total restraint required from baulking arrangements and the remaining half from lashings and load friction.

## ANCHOR POINTS

Traditional rope hooks or rings and the method by which they are attached to the vehicle structure are only suitable for the restraint of light loads. For this reason, platform vehicles in particular should be equipped with load anchorage points, designed and integrated into the structure so that the maximum forces likely to be imposed on them are transmitted to the main chassis frame of the vehicle. It is common practice to utilise the coaming tie rails, and in the case below, it is necessary to tie in the vicinity of the cross member and tie rail junctions to prevent distortion of the tie rail (see figure 6).

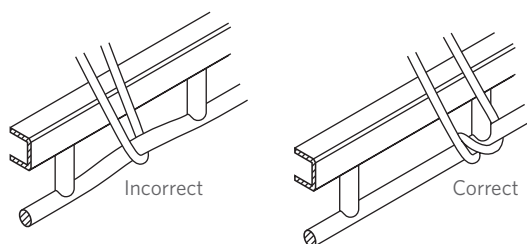


Figure 6

Each anchor point must have a strength at least equal to the rated strength of the lashings secured. All vehicles must comply with NZS 5444 *Load anchorage points for vehicles*, in accordance with the Heavy Vehicles Rule.

Where load anchorage points are provided, they should suit the type and payload capacity of the vehicle and the nature of the load to be carried. Twist locks for containers are not regarded as anchorage points for other loads.

When it is feasible to modify existing vehicles to include anchor points, their mounting must in no way weaken the chassis/body structure. In particular, no holes may be drilled in the top or lower flanges of the chassis side members. Welding to the chassis without the approval of the original manufacturer or another reputable manufacturer is not recommended.

Trucks fitted with tipper bodies should have a clamping device to secure the front of the body to the chassis when the vehicle is being used for general freight, etc.



## LOADING RACKS AND HEADBOARDS

For safe loading every vehicle should, if possible, be fitted with a loading rack or headboard. Otherwise twice the strength of lashings are required. The design of this loading rack or headboard should be consistent with the type and nature of the load being carried.

Loading racks or headboards fitted to the front of the platform of a vehicle used for the carriage of miscellaneous loading must be capable of withstanding a horizontal force uniformly distributed over the vertical area equal to half the rated payload capacity of the vehicle.

The headboard should meet the following requirements:

- Width should be at least equal to the width of the cab and for preference should be equal to the width of the loading platform.
- Height will depend on the kind of load the vehicle is designed to carry. It must be sufficient to obstruct forward movement during deceleration unless adequate load restraint is provided by other means, but should be a minimum of 0.5 metres high.
- If a trestle type headboard or bolster is fitted behind the driver's cab to support long loads, the trestle or bolster must be capable of resisting the combined effect of two forces each equal to half the permissible payloads acting forwards and downwards through the top of the trestle or bolster.

### *Specifications for headboards and cab guards*

Some loads, eg coils, sheet steel, pipe, structural steel, timber are more prone to movement under extreme circumstances, Rapid deceleration or an accident can cause the loads to shift and this can result in the penetration or crushing of the vehicle cab. When dealing with such loads, the vehicle, in addition to having the load secured properly to anchorage points, should be equipped with an adequate headboard or cab guard. These must be of sufficient strength to resist any penetration or crushing of the driver's compartment when involved in an accident or subject to emergency braking deceleration.

Where possible, loads should be placed tight against the headboard or cab guard. If this is not possible, additional packing or chocks should be placed between the headboard or cab guard and the load to prevent any initial movement.

Headboards and cab guards should be high enough to block the forward motion of any item loaded on the vehicle. Alternatively they should extend from the platform of the vehicle to a height of 1 metre. Such headboards or cab guards should be as wide as the vehicle itself.

Headboards and cab guards should be secured to the platform structure to ensure adequate transfer of forces to the vehicle structure.

Headboards should be of solid construction without apertures and may be made of steel, aluminium or wood.

In the case of closed vans of 3.5 tonnes gross weight or more where the driver's cab is integral with the body, the transverse headboard behind the driver must be the full height of the load compartment and of sufficient width to afford adequate protection.

### ***Side gates and rear gates***

When fitted to the rear and side of the vehicle platform, they must be capable of withstanding a horizontal force uniformly distributed over the vertical area equal to half of the payload mass.

### ***Side and centre posts***

When in use they must be capable of withstanding a horizontal force uniformly distributed over the vertical area equal to half of the payload weight. Side posts should be arranged or braced so that the width of the vehicle, when laden, does not exceed legal limits. Also posts should be designed such that they cannot unintentionally become detached from their holders.

# Load-securing equipment

## SELECTION

What you select as a means of securing a load on a tray truck or trailer platform will depend to a large extent on the type and construction of the load to be carried. Clamps, special bolts, steel wire rope, chains, webbing straps, rope and cordage made from natural and synthetic fibres, and shoring bars used in vans are all suitable devices. Rope, cordage and webbing straps, whether made from natural or synthetic fibres, should be used with caution as their strength cannot readily be assessed and can be seriously weakened by age, wear or incorrect use.

## ROPE OR CORDAGE

In view of the continuing proliferation of various grades and quality of rope on the market, prospective purchasers of rope should, for their own protection, insist on the following information, provided by the supplier, in writing:

- Does the rope comply with AS/NZS 4345?
- What is the material and construction of the fibre?
- What is the minimum breaking force?

Where the above information is not available or there is doubt, samples should be tested by either the supplier or an independent party that is acceptable to both purchaser and supplier.

### *Specification of rope*

Rope should be 12mm in diameter and manufactured from one of the following fibres:

- Polypropylene film.
- Polypropylene mono, or multi-filament.
- Polyester filament.
- Polyamide (nylon) filament.

The list shows the materials arranged in their order of preference. Light (UV) stabilised material should be used where there is a choice. If rope is sold as light stabilised grade, the supplier should be able to substantiate such a claim.

Ropes should preferably be manufactured and supplied in accordance with AS/NZS 4345.

Manila ropes and 12mm sisal should not be used other than for securing tarpaulins and loads less than 0.5 tonne.

## Inspection of ropes

Ropes made from any material are liable to wear. They can be weakened by various agencies such as chemicals, heat and light or by excessive knotting, bending or chafing. Regular inspection is necessary to ensure that the rope is still serviceable.

Examination at intervals of about a metre at a time is desirable, the rope being turned to reveal all sides and the strands being untwisted slightly to allow examination between the strands.

To define a standard of acceptance or rejection is much more difficult than to describe the method of inspection. There can be no well-defined boundary between ropes that are safe and those that are not because this depends on the stresses placed on a rope. The decision whether to use a rope or to replace it must depend on an assessment of its general condition. If, after examination, there should be any doubt about its safety, it should be withdrawn from service.

Fibre rope is easily damaged and this potentially dangerous condition is not always visible. Constant vigilance throughout the life of the rope is therefore essential in the interests of safety.

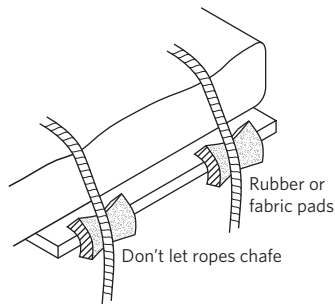


Figure 7

## CLAMPS

Purpose-made clamps are suitable for loads, eg containers where special lifting pockets, brackets or attachments are fitted to the loads (see pages 26-31). In most cases, it will be necessary to reinforce the platform of the vehicle in the vicinity of the clamp position. The design of the clamp and reinforcement should be carried out in accordance with sound engineering practice. It must meet the strength requirements of the necessary load restraint and be compatible with the structure characteristics of the vehicle. Where clamps are used, a minimum

of four should be fitted and three of these must be strong enough to restrain the load if one clamp fails to function correctly.

## STEEL WIRE ROPE

Steel wire ropes made up into special straps or slings are suitable for securing a load when used in conjunction with other suitable devices, eg shackles or thimbles. They are not as commonly used as steel chains. The strength of the steel wire rope will depend on the quality of the steel used, the number of strands, the number of wires in each strand, the diameter of the rope and the method of construction. The rope should be free from rust and there should be no broken wires or strands. Apart from the risk of injury to personnel from contact with broken wire strands, if 10 percent or more broken wires are visible in a rope length equivalent to 10 rope diameters, the rope is unsafe and should be condemned. There is a risk of unseen internal corrosion with steel wire rope and it can be easily damaged if driven over or bent around a sharp corner, etc. Therefore, the use of chain is preferable.

Those responsible for the purchase of wire rope and fittings for use in load restraint systems should ensure that they comply with AS 3569 or BS 302.

## CHAINS

Chains may also be used for lashing loads. A number of factors determine the strength of chain – size and grade of material, link dimensions and heat treatment. Chain used for load restraint purposes is required to possess special mechanical properties for this demanding application. For specifications refer to appendix B.

All chains must comply with AS/NZS 4344 or BS 4942.

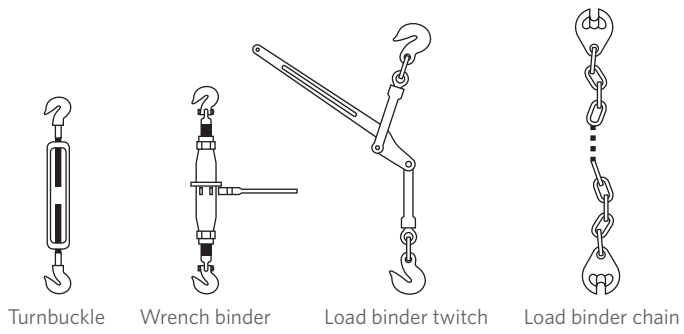
Load binders and turnbuckles should be at least as strong as the chains to which they are attached. The use of grab hooks reduces the strength of chain by 25 percent and, as such, the lashing capacity of this type of system must be reduced by 25 percent. Clevis claw hooks do not reduce chain strength and should be used in preference. The hook of the binder should not be spread or distorted. The attaching pin should not be bent, worn over 10 percent of its thickness or inadvertently secured to the hook. The binder parts should not be bent, repaired by welding or so worn or distorted that the chain cannot be tensioned properly or retain tension when in the secured position.

All chains used for load restraint purposes should be clearly identified with links quality marked at regular intervals, to provide protection against the use of chains of unknown quality. Chain should be of 'short-link' formation because it is more resistant to deformation than other formations. When turnbuckles or load binders are used in conjunction with chains they should correspond in strength

with the chain used. Any distortion of load tensioning devices clearly indicates that severe overloading has occurred and such items should be removed from service. Welded repairs to turnbuckles or load binders are not permitted as this can result in subsequent failure. When tensioning devices are not capable of applying or retaining tension, they should be removed from service.

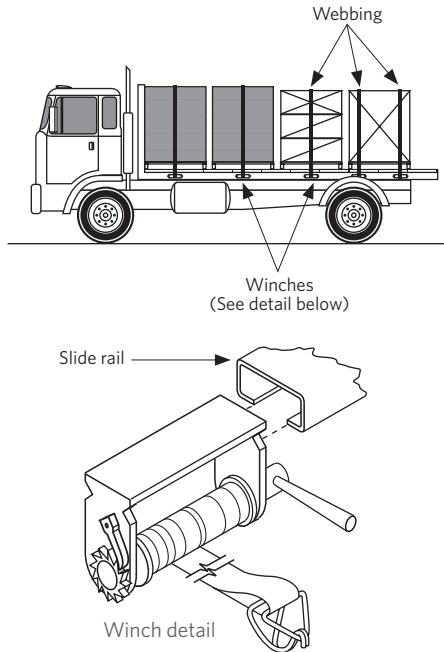
The following safety precautions must be taken when using and inspecting chains:

- Chains securing loads should be tightened using turnbuckles, or load binders securely locked. All securing requirements must be met prior to the vehicle beginning its journey. The load should be checked at intervals as recommended in the introduction (pages 5–6) and on page 48. Load binders, twitches and chains can be dangerous. Do not stand too close while operating them.
- Chains should extend over the load with each end attached to opposite sides of the vehicle approximately opposite each other. The number of chains should be sufficient to ensure the proper securement of all loading on the vehicle in accordance with the weight distribution of the load and the location and strength of anchor points.
- Chains should be secured to anchor points by either a permanent attachment, a shackle type coupler or by the use of a grab hook. Rope rails should not be used as anchor points, but stake pockets having an equal strength to the chain may be used.
- Chains, turnbuckles, load binder attachments and anchor points should be maintained in good condition. Under any of the following conditions, the chain or other components should be condemned and replaced:
  - Cracked links in chains, load binder attachments or welds.
  - Bent, twisted, stretched or collapsed links.
  - Links weakened by gouges or pits reducing the diameter by 10 percent.
  - Chains repaired or joined by repair links of a type other than those designed for the purpose.
  - Links obviously worn or showing other visible evidence of loss of strength, by 10 percent or more.
  - Knots in any portion of the chain.
  - Spread or distorted grab hooks.
  - An anchor point used in the securement of the load that is in a weakened condition or shows evidence of loss of strength because of cracks, breaks, distortion or other deterioration.
- Care should be exercised not to overstrain chains or binders by the excessive use of pipe or pipe lever extensions.



**Figure 8** Detail of load binder

Hinge pins should be parallel or positive locking means employed to prevent link spreading.



**Figure 9**

## WEBBING AND STRAPPING

Commercial webbing and strapping, specially designed for lashing loads to vehicles, are available. These incorporate quick-fastening release hooks and tensioning devices, and occasionally include anti-chafing sleeves (see figure 9).

Webbing made from synthetic fibres is slightly elastic in use. This prevents the load from working loose.

Where webbing is used as a means of primary restraint it must show no signs of damage, chafing, fraying or stitching failures.

The following points should be considered when selecting webbing type restraint equipment for use with palletised loads:

- The webbing and attachments complete with tensioner must comply with AS/NZS 4380.
- The general construction of the assembly should be adjustable in length, incorporate a tensioner and have an overall length of approximately 9 metres. It should be provided with a hook and keeper at each end.
- The hook and keeper, which should be made of steel, should be suitable for hooking to 12mm or 22mm diameter rod or rings of inside diameter 38mm if formed of 12mm diameter rod, or 50mm inside diameter if formed of 20mm rod. Rubbing plates should be provided if there is a risk of the webbing chafing where it passes through the hook and keeper. A keeper should be fitted to prevent the accidental release of the hook.
- The webbing should be at least 38mm wide. The stitching should be sound and webbing ends should be properly heat sealed.
- The tensioner should be of a simple type, preferably without loose parts. It should be capable of being readily operated by one person and be capable of taking up a minimum of 76mm of slack webbing. It should include some mechanism that prevents it from releasing the tension when subjected to vibration from the motion of the vehicle.

### *General guidelines*

When webbing is used, the vehicle should have at least one lashing every 1.5 metres along the length of the load. Complex loads are likely to require additional lashings. Each part load or load that is not loaded against a headboard or baulked must have a minimum of two lashings.

Where rope is used, knots must be correctly made and the lashing scheme arranged so that failure of one length of rope does not lead to failure of the entire lashing. It should be borne in mind that rope made of natural fibres will stretch when dry, allowing the load to move. When wet it is liable to shrink with the risk of damaging the load and jamming the securing points.



In general, the method of securing any load must be decided by the type of load. It is therefore strongly recommended that owners equip themselves with the correct type of securing equipment for the type of load carried. Where general cargoes are carried, various types should be made available.

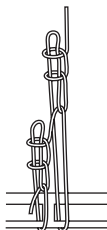
## KNOTS

The following illustrations indicate some of the more common knots used with ropes and cordage for load securing purposes.

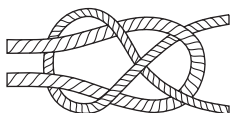


**Figure 10** The sheepshank

The sheepshank or truckie's hitch is used for tightening ropes used to secure loads. Where a tie rail is used to attach a rope, the anchor point should be adjacent to a cross member.



**Figure 11** Truckie's hitch  
Double shank/double hitch.



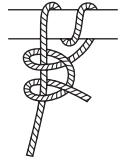
**Figure 12** Single sheet bend

This is used to join two lengths of rope together, eg if a belly rope is required on a load and the ropes are too short and where the knot itself will not bear on anything.



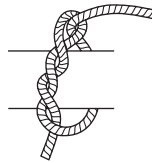
**Figure 13** Clove hitch

This is most commonly used by truck operators for fastening the end of a rope.  
With this knot, a stopper (ie two half hitches) should be used.



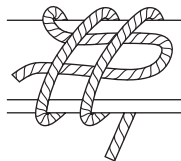
**Figure 14** Round turn and two half hitches

This is a safe knot for fastening the end of a rope.



**Figure 15** Timber hitch

This can be handy for fastening when an object requires moving.



**Figure 16** Towing hitch

This is handy if the vehicle requires towing for a short distance by rope as it will not or should not jam, and a jerk on the end will release the tow.

# Specialised requirements

## Containers

### SELECTION AND SPECIFICATIONS

The freight containers mainly transported are constructed to international standards (ISO) and are identifiable as such by their external markings (refer AS/NZS 3711 Pts 1-10).

They are made to nominal lengths of 12 metres, 6 metres and 3 metres with a width of 2.4 metres and heights of 2.4 metres, 2.6 metres and 2.9 metres.

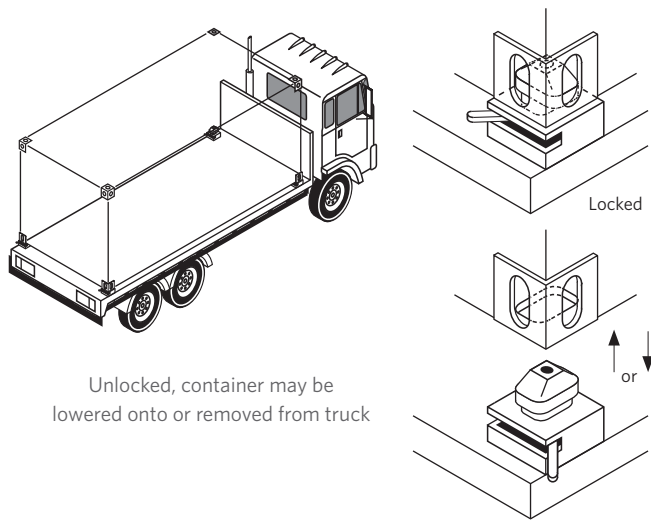
It is essential that the driver checks the overall height of the vehicle from the ground with respect to bridge heights and overhead obstructions expected en route. Vehicles carrying empty containers ride higher than loaded containers. Fleet operators will find a height loading gauge useful at yard exits.

A feature of all the containers mentioned above is they are equipped with specially designed corner castings that are provided for both lifting purposes and as a means of securing the container when it is being transported. There are also containers that are not built to these standards. These containers may be secured by specially designed restraint systems.

Safe methods for the carriage of containers will therefore vary according to the type being transported and the securing attachments provided on the carrying vehicles.

As mentioned above ISO containers are fitted with a casting at each corner. This enables them to be securely attached to the carrying vehicle by means of specially designed locking devices known as 'twist locks' (see figure 17). A vehicle properly equipped for carrying containers has twist locks built into its structure at appropriate spacings to line up with the corner castings on the container(s) that it is designed to carry. Provided the twist locks are then fully engaged and properly locked, the container may be regarded as being secure.

Where provision is made for the use of twist locks they should always be used. Advantage should be taken of any adequate inbuilt locking device.



**Figure 17** Typical twist lock or tie down instalment

### ***Containers carried on vehicles not equipped with twist locks***

It is important that all vehicles used to carry containers are fitted with a securing device.

A container should never be carried when insecure, whether it is loaded or otherwise. Securing devices other than twist locks should be of an acceptable configuration (see figure 18). Ropes, chains or webbing should only be used for securing sea freighter containers and newsprint bases.

As explained elsewhere in this code, a load carried on a vehicle without the use of restraining devices will not be secure because the frictional restraint between those parts of the load in contact with the platform of the vehicle will not always prevent it moving when the vehicle brakes or changes direction.

### ***Use of adaptor frames***

Adaptor frames are sometimes used. Adaptor frames usually incorporate twist locks. Frames should be suitably bolted or securely fixed through to the chassis. If in an emergency a need arises to carry a container on a vehicle not specifically designed for that purpose, the container must be secured in a manner defined for large indivisible loads (see pages 47-59).

## Securing points on the container

Lashing or securing devices used should only be attached to those fitments on the container intended to facilitate its lifting or mechanical handling when laden, eg lashing rings or corner castings on cargo flats. These fitments should be examined to ensure that they are in sound condition, and all of them should be used to secure the container to the vehicle platform.

## Anchor points on vehicle

The number of anchor points used will be decided by:

- the need to position the container to achieve the correct load distribution
- the extent to which other load restraint features are incorporated in the design of the vehicle
- the weight of the container to be carried.

There should never be less than four anchor points used in any circumstances, ie two per side.

It is essential that the stresses transmitted by the securing devices are ultimately absorbed by the vehicle's chassis frame. Anchorages must therefore be fixed securely. Each anchorage should be capable of withstanding its rated capacity acting in the direction of the side members within an included angle of  $10^{\circ}$  to  $60^{\circ}$  to the horizontal. To achieve this it may be necessary to strengthen cross members by the use of stays or bracing secured to the vehicle's chassis. Rope hooks are not strong enough for anchorages and must on no account be used for this purpose. Chaining containers to the rope rail of a vehicle must not be permitted.

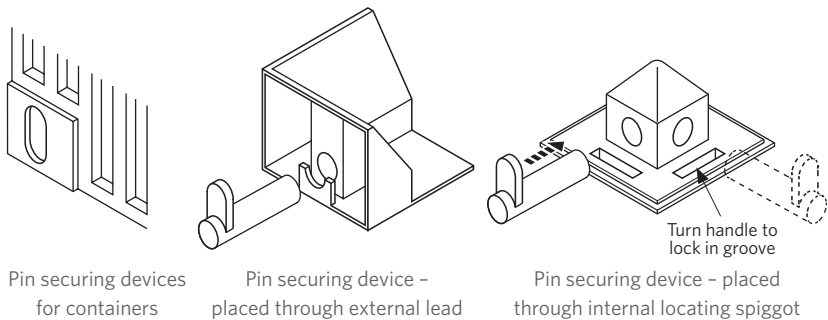


Figure 18

## *Securing devices*

All devices used for securing a container should be suitably constructed in accordance with recognised engineering standards and should be adequate for the job for which they are designed.

Purpose-made restraining devices are suitable where special lifting pockets, brackets or attachments are fitted to the container. A minimum of four devices should be used and three of these should be strong enough to restrain the container if the other clamp fails to function correctly. In most cases it will be necessary to reinforce the deck of the vehicle in the vicinity of the device position, ensuring the weight is transferred to the vehicle chassis. The design of the device and the reinforcement should be carried out in accordance with the recommendations of the vehicle or trailer manufacturers.

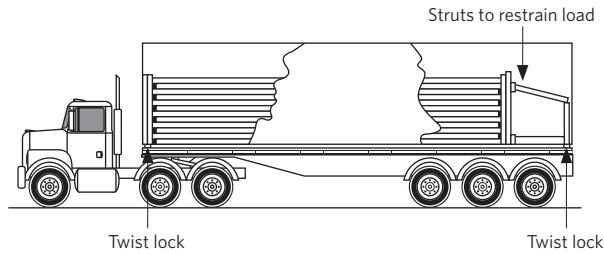
## *Loading arrangements within containers*

Incorrect loading of a container may result in dangerous situations occurring when the container is handled or transported. Serious damage may be caused to the goods carried. In many instances the driver or vehicle operator will have no control over the packing of a container and will not be able to inspect its contents when accepting it for movement.

If a container is unevenly loaded with its centre of gravity offset towards one side or one end then there is a risk of it tipping when lifted. When it is loaded on the vehicle there is a risk that the vehicle's axles will be incorrectly loaded and the stability of the vehicle adversely affected. Inadequate stowing arrangements within the container may result in the load shifting, which again may cause a dangerous situation. If it is then apparent that the container has not been safely stowed, it should not be accepted.

The following general stowage principles that affect road safety must always be observed:

- Light goods should be stowed on the top of heavy goods.
- A container should be filled so that the weight of goods is evenly distributed over the floor area.
- If the container is not fully stowed, the goods already stowed must be strapped or otherwise restrained (see figure 19).
- If the container is fully loaded, the internal securing arrangements must be suitable to restrain the full weight of the loads.



**Figure 19** Suggested method of loading a container

## TYPES OF CONTAINERS AND VEHICLES

### *Tank containers*

The stability of vehicles carrying liquids and especially dangerous goods in tank containers is an important safety issue. Loaded tank containers should be transported on low bed trailers.

**Note:** It is important that the low bed trailer is fitted with twist locks.

### *Platform containers (flat racks)*

Most shipping containers and flat platforms of all types used in road transport comply with ISO requirements. The platform container is primarily used for heavy lift and out-of-gauge cargoes. They are equipped with corner castings designed to interlock with mating twist locks for either lifting or securing them for transport.

Platform containers have load anchor points to facilitate the lashing of loads to the platform. ISO requirements specify a minimum rating of 3000kg for anchor points on the base structure and 1000kg for those located elsewhere, eg lashing rings on the platform floor. These anchor points do not require additional certification to NZS 5444 *Load anchorage points for vehicles*.

A platform container must be secured on a vehicle fitted with four compatible twist locks, and may be transported only if all loads on the platform are adequately secured. The twist locks must be fully engaged and properly locked. If it is not possible to adequately secure a load to the platform container, then additional lashings must be placed over the load and attached directly to the vehicle's anchor points.

Some platform containers can be stacked and secured for transport when empty by using all built-in positive lock fittings (usually twist locks or ring and bolt connections). It is important to check that the platform containers are

compatible to lock together. All platform containers that meet ISO standards can be stacked and secured for transport using four interlocking double twist locks between each layer.

### **Do**

- check platform containers are in serviceable condition, especially the corner castings and any built-in locking systems
- use all twist locks to secure the platform container to the vehicle
- check that the load is adequately secured to the platform container
- use all interlocking double twist locks between each empty platform container within a stack that is to be twist locked to a vehicle. Alternatively, platform containers with compatible in-built positive locks can be used to secure each layer in a stack.

### **Don't**

- accept a stack of empty platform containers that cannot be positively locked between every layer
- weld platform containers together in an effort to avoid using double twist locks or as a means to secure incompatible bases together
- fasten loads to platform containers using steel or PET strapping as the primary load restraint, unless the strap's rated strength is readily identifiable.

**Note:** The efficiency of the locking mechanism (crimp or seal) will dictate the strap's rated strength.

### **Enclosed-bodied vehicles (including curtainsiders)**

The principles of packing and stowing applicable to containers also apply to general freight vans and curtainsiders. It is important that the load cannot move relative to the vehicle. This means that contained loads within vehicles with adequate sidewall strength or curtain rating should be packed tightly together within the vehicle's body to prevent any movement, otherwise the load will need to be restrained as though it were on an open decked vehicle. Loads that are further than 100mm from the sidewall or curtain must be fully restrained. The exception is one or two small individual items that each weigh less than 25kg. Load separators such as shoring bars should be used where necessary to restrain individual items. Where parts of loads are added or removed during a journey, the load should be rearranged and re-secured to maintain correct load distribution and restraint.



# Pallets

Pallets represent a two-fold problem from the point of view of load security. Firstly you must consider the stability of the items stacked on the pallet and then the security of the pallet on the vehicle platform.

## BASIC SAFETY PRINCIPLES

The pallets should be of sufficient strength to withstand the load they carry satisfactorily and should be in a good state of repair. Full pallets must be constructed and bound so they are able to withstand a horizontal acceleration of 0.5g (half weight of pallet). If there is any doubt concerning this capability then a simple tilt test should be carried out.

The pallet must be able to withstand a sideways tilt angle of at least 26° before showing signs of any significant distortion.

The securing method adopted will depend on the type and size of the vehicle, the position and number of anchor points, and the size, weight and number of pallets in the load. However, the following principles should be followed for whatever scheme is chosen:

- Vertical and tipping motions should be prevented by securing a tarpaulin across the load and then by a rope placed across the top of the tarpaulin over the pallet load, as shown in figure 20.
- Forward and rearward movement should be prevented by restraints passed around the base of the pallets, as shown in figure 20.
- The rope should not be attached to or passed under the strapping or binding used to secure the load to the pallet.
- Cross lashings must be such that each pallet on the top layer has at least one cross lashing. Any pallet that is above the general height of the load should have at least two cross lashings.

Pallets must not be used for carrying the following:

- Metal or plastic drums of 50 or 200 litre capacity except where they are secured to the pallet or loaded as specified on pages 35–46 of this code.
- Plastic containers because of the difficulty of preventing sideways movement on the pallet and hence keeping lashings tight so that the load remains secure.

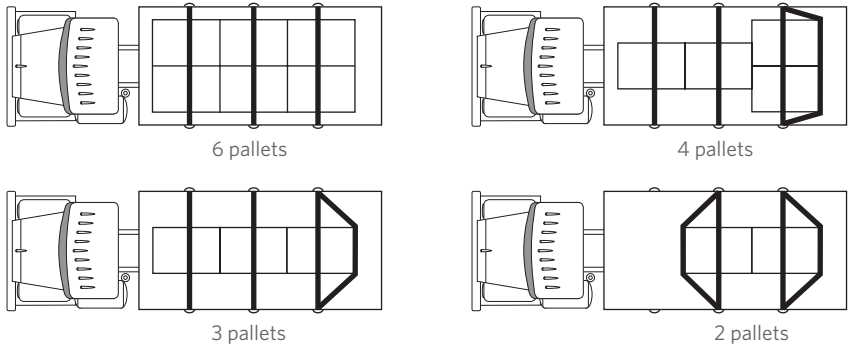


Figure 20

### STEEL DRUMS - 200 LITRE CAPACITY

Two-hundred litre drums on wooden pallets must only be carried on vehicles equipped with headboards. Pallets must be placed side by side across the vehicle deck starting from the headboard and working to the rear of the deck. Single pallets must be placed centrally across the vehicle deck.

Drums on pallets are to be secured to the deck by ropes or straps bearing on wooden corner boards. The minimum dimensions of the corner board are shown in figure 21. Drums must be secured by a corner board at each side of the vehicle. At least two ropes or straps must bear on each corner board as shown in figures 22 and 23.

Corner boards must rest on at least two drums. There must be at least one rope or strap bearing on the corner board across each row of drums.

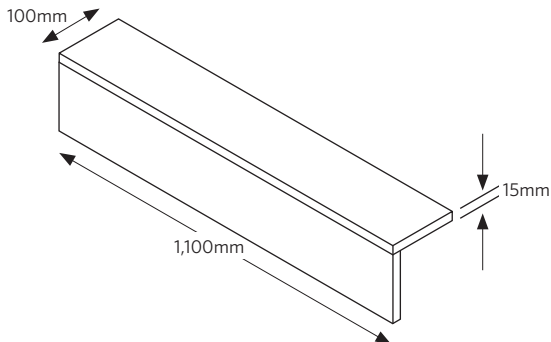
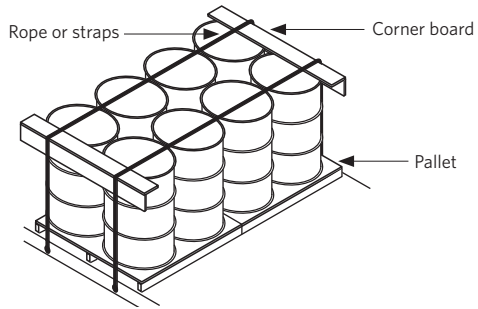
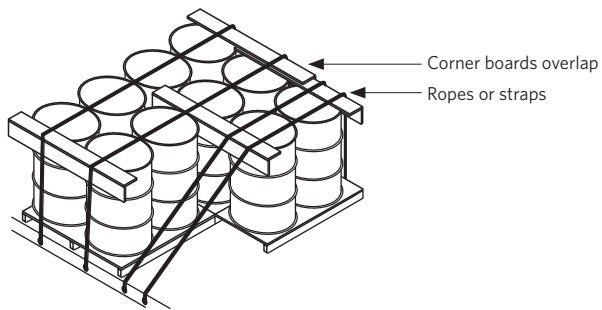


Figure 21 Wooden corner board detail - minimum dimensions (mm)



**Figure 22**

Drums must be loaded on pallets in even numbers. Odd drums must be loaded singly in accordance with figure 36 in the general freight section (page 43).  
Chains are not to be used to secure drums.



**Figure 23** Securing method for 4-drum and 6-drum pallets

# General freight

## SYMBOLS ON THE LOAD

There are certain symbols marked on cargo to and from overseas that are recognised universally.

All indicate general handling instructions to handlers of cargo who may speak a different language.

The symbols should measure over 100mm in height and be painted in black on a light background or white on a dark background. They can be in the form of a label or stencilled directly on to the package.

Several different symbols may be used on one package for varied instructions. In general, these should be placed in the upper left and right-hand corners of the main vertical face of the package and repeated on each vertical face, if possible. However, the 'keep away from heat' and 'sling here' marks are usually placed on the lower vertical face.

The common symbols are shown in figure 24.

The loading and securing of general freight loads on goods vehicles is made difficult by the wide diversity of shape, size and nature of this type of load. Vehicles equipped with side gates or van bodies will provide some restraint to movement of the load. However, additional load-restraining devices may still be required under the following conditions:

- If there is a risk that the load may break through the walls or side gates of the vehicle.
- If the load is higher than the loading racks or side gates of the vehicle.
- If the load is liable to be damaged because it moved during transit.

When general freight loads are carried on platform vehicles, some form of load restraining device will always be required.



Figure 24 International cargo symbols

## LOAD ARRANGEMENT

Two essential requirements must be satisfied when loading vehicles, namely the load must be distributed so that:

- the maximum vehicle and axle weights are not exceeded
- maximum stability is ensured when the vehicle is braked, accelerated or changes direction.

For maximum stability, the items that comprise the total load need to be evenly spread to achieve minimum height and to form a unified whole so that no excessive stress is applied to whatever restraining devices are used. Where a part of the load is to be picked up or removed in the course of a journey, the effect on gross vehicle weight, individual axle loadings and the securing and stability of the load being carried must not be overlooked. Although the removal of part of the load will reduce the aggregate vehicle weight, it may change the mass distribution, and this possibility must be borne in mind during the initial loading operation.

In addition to the general principles outlined above, the following procedures should be followed whenever applicable:

- Where mixed loads, such as heavy, solid articles and light crushable boxes, etc are involved, the former should provide the base and forward parts of the

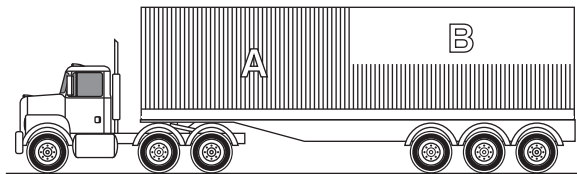
load. The light portions should be loaded on top and to the rear, provided the load arrangement does not overload the prime mover axles (see figure 25).

- Throughout the journey, at every stop, the load should be checked for security and the lashings tested. Weather conditions can affect the tension of ropes and this may lead to damage of the load or loss of security.
- Where mixed goods in different sizes of container are involved, small items should be central with larger items forming the outer walls of the load. The smaller items should not be so low as to act as a pivot point for the larger items around the edge to tip either way, inwards or outwards.

It is possible for gas cylinders to be placed vertically in the centre of a mixed load (see figure 26).

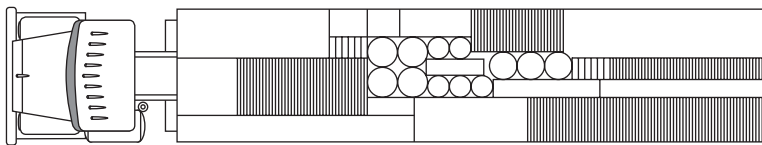
Plastic containers may be contained within the load, as illustrated.

- Keep irregular-shaped items for the upper part of the load when it is not possible to place them centrally within the load.
- The load must be packed tightly before applying restraint.



A. More solid or dense payloads forward or under.  
B. Light or crushable payloads rearward or top.

Figure 25



Large lifts to outside to contain smalls on inside of loading.

Figure 26

## RESTRAINT DEVICES

A variety of materials may be used for restraining general freight loads. These include rope, steel chain, steel wire rope and specially designed webbing strapping made up into a harness or net. For the securing of loads inside van

bodies and similar load containers, specially designed shoring poles used in conjunction with the appropriate securing fixtures on the vehicle deck and sides are suitable. Custom-built restraining devices should only be used as outlined by the manufacturer.

The restraining devices you use should be based on load securing principles (see pages 18–25). However, there are some special points that need to be considered when dealing with general freight and these are outlined below.

## *Tarpaulins*

Tarpaulins may be used subject to the conditions outlined on page 11.

Tarpaulins must be properly secured to the vehicle. Where several tarpaulins are required to cover one load they should be put on at the rear of the load first (see figures 27, 28, 29, 30). This ensures the overlapping portion of the tarpaulin faces rearwards, so preventing wind and driving rain penetrating between them. The same principle must be applied to folds in the tarpaulins at the front or on the sides of the vehicle, so that wind pressure is harnessed to close any gaps or folds in the tarpaulins.

In the case of multiple tarps position the sheets on the load ensuring that all parts are covered and that sheets are equal on each side, secure the front of the rear sheet followed by the rear of the front sheet. Do not overtighten or sheets will be drawn up to expose the load at the rear or at the front.

The next stage is to secure the front of the front sheet. This can be done in either of the following ways:

➊ Step 1: Draw in the surplus sheet from the sides, cross over the front and secure.

Step 2: Fold the cross-overs down. The remaining surplus sheet should form a full width flat front flap (see figure 28).

OR

➋ Step 1: Draw down the front end of the sheet and secure along the entire width of headboard or trailer body.

Step 2: Draw the surplus sheet forward at the front corner until the sheet lies flat against the load (figure 29). Secure one side of sheet from the front corner as shown in figure 29 left. Repeat on the other side drawing the sheet taut while tightening the second sheet.

Step 3: Fold back the triangular shape surplus sheet along the side and secure.

Having secured the front sheet, secure the sides of the rear sheet to the rear-most corners. The rear of the load should be sheeted and folded as illustrated in figure 30.

The following points should always be checked:

- The lights, reflectors, number plates and rear markings, etc should not be obscured.
- All loose rope ends should be tied up.
- There should be no loose flaps or tears in the tarp sheet liable to cause danger to other road users when the vehicle is moving. If damaged tarps cannot be replaced immediately, carry out temporary repairs and apply additional lashings (refer figure 31).

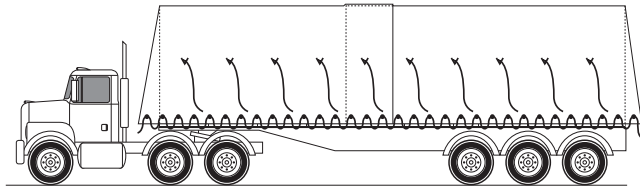


Figure 27

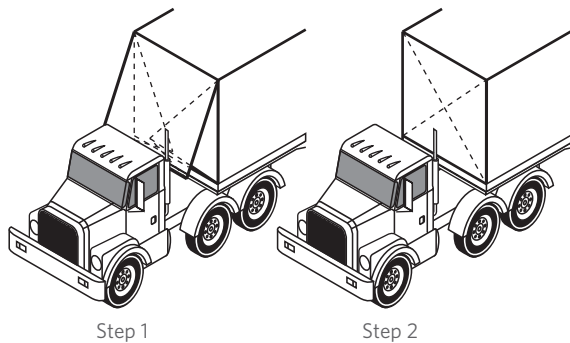


Figure 28

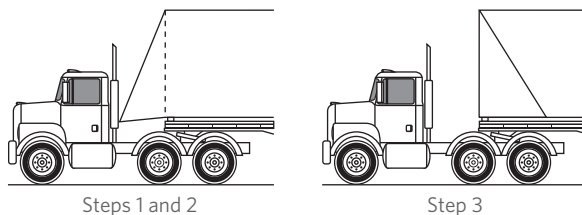


Figure 29



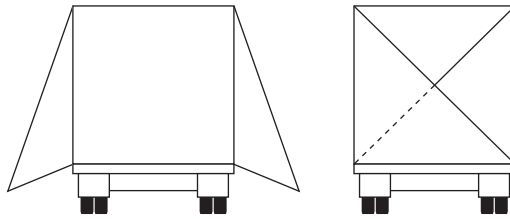


Figure 30

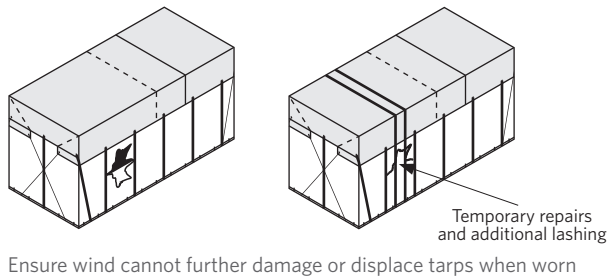


Figure 31

## LOADING METHODS

In view of the wide diversity of general loads, it is not possible to suggest loading methods for all types of loads likely to be encountered. However, the basic precautions outlined in the basic criteria and precautions section (see pages 8-13) will always be applicable. Loading methods for certain general categories of loads are outlined in the following paragraphs.

### *Rolls, drums or cylindrical loads*

If the length of the cylinders is less than twice their diameter, they should be placed on end unless instructions are given to the contrary. If the length is greater than twice the diameter, but less than the width of the vehicle, they must be positioned so as to roll forward. Each row must contact the one in front, and the front and rear ones must be chocked to prevent rolling backwards or forwards.

### *Steel drums - 200 litre capacity - individually loaded*

Wherever possible the vehicle you are using to carry drums should be equipped with either:

- headboards, sideboards and tailboards, or

➤ stanchions, ropes and hooks.

If this is not possible the vehicle must be equipped with cant rails and ropes must be used to secure the load as shown in the following figures. The drums are to be secured in groups of 8 and anchor points should be spaced no greater than 1 metre apart. All drums must be inside, NOT on the cant rail. The cant rails should be at least 3cm above the deck. You tie the first row before placing the second row.

Figures 32 and 33: Vehicle without headboard, sideboard, tailboard or stanchions. Drums in this case are to be loaded from the back and towards the front row to be double lashed as shown.

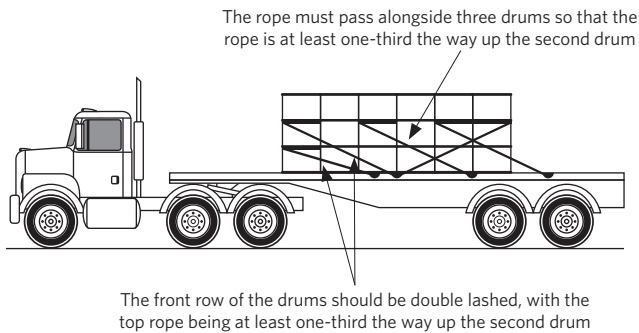


Figure 32

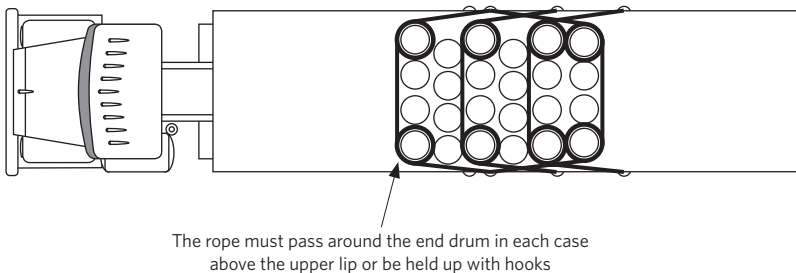
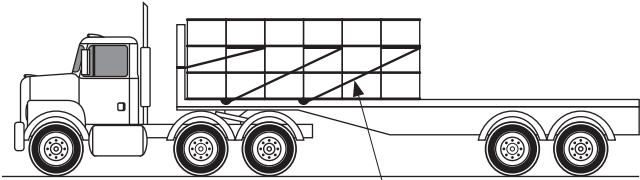


Figure 33

Figures 34 and 35: Vehicle with headboard but no sideboard, tailboard or stanchions. Load from headboard and back.



The rope must pass over three drums so that the rope is at least one-third the way up the second drum

Figure 34

The rope must pass around the end drum in each case above the upper lip or be held up with hooks

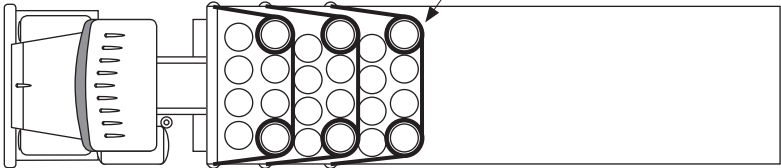


Figure 35

Figure 36: Vehicle without headboard, sideboards, tailboard or stanchions carrying less than eight drums.

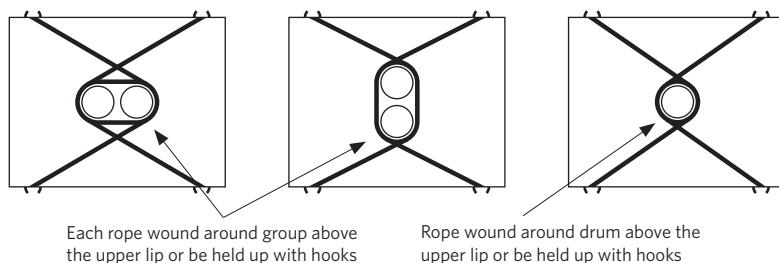


Figure 36

**Note:** Only this method should be used when drums are carried on their own. If drums are carried with different types of containers, where possible, they should be surrounded by other packages, if the packages are heavy enough to help steady the drums before other lashings are tied on.

The double stacking of full 200 litre drums is not allowed. However, empty drums may be double stacked, provided the vehicle is fitted with a specially constructed cage. On no account must steel drums be carried on a metal deck without the use of close-boarded dunnage or sheets of plywood as a base for the load. This is because of the ease with which metal slips on metal both when being handled in loading and when the vehicle is moving.

### **LOADING AND OFFLOADING OF HEAVY DRUMS**

Care should be taken not to damage either the vehicle or the drums to prevent spillage. Suitable skids and/or protective cushioning should be employed. This applies in the absence of mechanical handling equipment.

(Drums loaded on pallets - refer to pages 32-34)

### ***Small steel containers - approximately 50 litre capacity***

The same method of securing 200 litre drums outlined above must be used. The exception is where head, side and tailboards are fitted. In this case double stacking is permitted as long as the top layer is 50 percent below the top of the sideboard and the bottom layer of containers is capable of withstanding the extra pressures exerted by the weight of the top layer. As for the larger steel drums a metal deck must be covered with wooden dunnage.

## Plastic containers and plastic drums

Because of the difficulty in securing plastic containers and the ease with which they can collapse, a vehicle fitted with headboard, sideboards and tailboards or an enclosed vehicle must be used. If the plastic-contained goods form part of a load, stack the other goods around them to provide barriers between the plastic containers and the edge of the vehicle, and to hold the plastic containers steady. Plastic containers and drums must not be double stacked because of the risk of the bottom layer splitting under the weight of the top layer.

## Cartons and boxes

Boxes and cartons must be loaded so that they are prevented from moving in any direction. They must interlock if possible, and be loaded to a uniform height. Heavier boxes should be at the bottom of the load.

Tarpaulins may be used to secure very light bulk loads. However, for heavier loads there must be one lashing for each row of boxes across the vehicle under the tarpaulin. Any box that is above the general height of the load must have at least one cross lashing, and two if it weighs more than 0.5 tonne.

## Sacks

Sacks should be laid flat with alternate layers in opposite directions as shown in figure 37. In any event no more than two successive layers should be in the same direction. The load should be of uniform height when possible. There must be at least one cross lashing for each sack length, or one cross lashing for each two sack lengths if covered with tarpaulins securely fastened to the anchor points. With certain loads the use of tensioners may be desirable. This is particularly true of loads that tend to settle around the lashings.

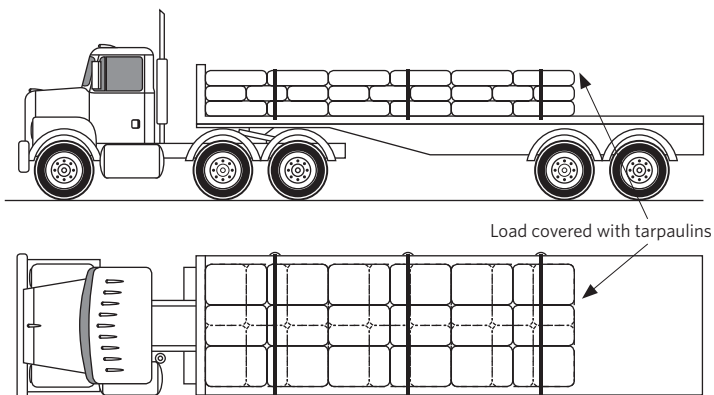


Figure 37

## Gas cylinders

All gas cylinders being transported by road should always be fitted with a valve cap or suitable guard to protect the valve from striking the road surface if an accident occurred.

Gas cylinders should be placed with their axis across the vehicle so that the rolling tendency will be to the front or rear. A vehicle with a metal deck must not be used for the carriage of gas cylinders.

Vehicles with headboards, sideboards and tailboards are to be used when transporting gas cylinders. The cylinders must be laid against each other, placed against the headboard and chocked at the back by means of a spiked chock. Stanchions may be used at the back so long as they are close enough to prevent any forward or back movement of the cylinders. The cylinders may be stacked on top of each other but may not project above the top of the sideboard.

If a vehicle with sideboards, headboard and tailboard is not available, spiked chocks must be used at both ends of a row and baulked against sideways movement along the entire length of the load. In this situation only one level is permitted, ie no stacking.

**Note:** The gas cylinders referred to here are the long, narrow type holding compressive gases or liquids under 250 litres water capacity and not the squat type with a bottom ring to stand upright that should be secured similarly to steel drums. Also some gas cylinders, such as those containing LPG, are required to be transported upright (ie with their long axis vertical) and therefore should be secured against a headboard similarly to steel drums.

## Glass

This type of load would normally be carried on custom-built vehicles embodying specially designed glass clamps and supports. However, when sheet or plate glass is carried in crates or timber pallets the load restraint precautions for general freight apply.

The transport of crated drink, milk or other glass bottles and containers constitutes one of the greatest potential hazards for other road users because of the risk of falling crates and the breakage and scattering of broken glass on the roadway.

Crates should therefore be adequately restrained unless they lean towards the centre of the vehicle in built-in compartments. All vehicles used for this purpose should be fitted with substantial loading racks and tail gates. Vehicles used for anything other than local delivery should be fitted with side gates.

Crated bottles and other glass containers should not be stacked on the platform to a height greater than the loading rack and tail gate.

## **Bricks**

All restraining systems must restrain the bulk mass of the load as well as individual bricks. These requirements can be met by load-surrounding sides, headboard and tail board, all of which satisfy the requirements given on pages 16-17. The load height should not exceed the height of the surrounding body. Custom-made nets may also be used for securing this type of load, providing the strength of both the net and the securing points used are equal to the load being restrained. Tarps should only be used as weather protection subject to the conditions.

It is now becoming commonplace to transport new bricks in bound bundles or shrink-wrapped on pallets on a platform truck with its own built-in loading and unloading device.

In such cases, the pallets of bricks must conform to the pallet requirements (pages 32-34), the bundle of bricks being constrained by steel bands, etc.

In spite of the steel-banding of bricks, individual bricks are liable to work loose during transport and fall to the roadway creating a hazard to following or passing traffic. Drivers must therefore be extremely vigilant towards the security of their loads. Because of potential traffic hazards of dislodged bricks, restraints with caged sides are recommended.

## **Mixed loads**

When a load is composed of different items – both goods and types of containers – each part of the load must be secured with cross-lashings in a manner suitable to the type of load. The longitudinal lashings, however, should be adequate for the total weight of the load. Separators must be used so that no part of the load can move forwards or backwards independently.

## **Wool**

In the transportation of wool, bales must be evenly distributed over the vehicle platform and the aggregate weight of the vehicle must not be exceeded. For the security of the bales during transport, double-ended spikes are to be secured across the loading and firmly attached to the tie bars or anchor points on each side of the vehicle. Ensure that all bales on the load are roped.

Again drivers and operators should at all times ensure that the loading is properly secured.

# Construction equipment

This section is intended to provide guidance on the prerequisites for the safe transportation of both track and wheel types of construction equipment on vehicles. The transportation of extremely large equipment on special purpose vehicles authorised by overweight and/or overdimension permits must be secured in accordance with the applicable sections of these guidelines, particularly in the basic criteria and precautions section (pages 8–13).

Heavy construction equipment is normally transported on vehicles designed specifically for that purpose and provision is made to facilitate loading, unloading and securing of the load. Lighter machines may be transported on general-purpose vehicles provided the load restraint method is as secure as that of a specially constructed vehicle.

When vehicles are being driven onto a tilt bed, helpers should be cautioned to stand clear of the front of the tilt bed platform.

## **BASIC SAFETY PRINCIPLES**

When a vehicle is carrying a load such as a wheeled or tracked vehicle, the load will be subject to forces that will tend to cause it to move. These forces will arise when the carrying vehicle is braking, accelerating, cornering or moving over an undulating or rough surface.

### *Practices to be discouraged*

In addition to the movement of the complete load there is a risk in some instances that part of the equipment (eg booms, superstructure) may have freedom of movement, and this can lead to dangerous situations arising when the vehicle is in motion and the load is subjected to the forces mentioned earlier.

If for some special reason a wheeled or tracked vehicle is positioned on the carrying trailer and not lashed down it would only be restrained from movement by its own skidding resistance if its brakes are applied.

Restraints must be provided. Even in normal driving situations the practice outlined above is inadequate. Additional restraints should take the form of a lashing system and some arrangement where the load is prevented from moving either forward or to the rear by an obstacle (or obstacles). These are securely fixed to the vehicle. They butt against the wheels or tracks or some other part of the equipment carried.

High loads risk contact with overbridges and overhead power lines. Since loads with a high centre of gravity will seriously affect the vehicle's stability, such construction equipment should only be transported on vehicles with a low



platform. Clearance heights along the route to be travelled should be checked against the loaded height of the transporter before travelling.

## **GENERAL SAFETY PRECAUTIONS**

The following precautions should be taken when transporting construction equipment on a road vehicle.

All movable assemblies on the construction equipment such as jibs, buckets, booms, slewing superstructures and cabs, etc must be left in the position recommended for transportation by the manufacturer. They must be secured to prevent movement relative to the main body of the machine. Do not rely entirely on locking devices built into the machine.

The loaded machine should be inspected after the vehicle has been driven for a short distance to check that no movement has taken place and that restraining devices are still secure. Periodic inspections should be made during the course of the journey, preferably at intervals no longer than one hour.

The adjustable restraining system should be so arranged that failure or slackening of one component does not lead to failure or reduction in the effectiveness of the remainder. Restraints must not be passed round or fastened to items that may move relative to the base machine.

The brakes of the machine should be applied. In addition, the machine should be left in gear provided that it is impossible for the engine to be accidentally started in this condition. Bags, tool kits or heavy objects should not be left loose in the operator's cab in case they knock the control levers, etc.

All twitches should be tied to prevent them releasing, causing a loss of tension in the chains, particularly when transporting rubber-tyred equipment.

## **LOADING ARRANGEMENT ON THE VEHICLE**

Before loading, the loading platform should be cleared of all debris. The positioning of the construction equipment and any of its detached assemblies must be arranged so that the maximum vehicle and axle weights are not exceeded, and the safe handling of the vehicle is not impaired. The clearance between the undersides of low-loading vehicles and the road surface should be checked before moving off where there is a danger of 'grounding', eg on an uneven railway crossing. The ground clearance of any motor vehicle and any trailer attached is measured from the horizontal road surface to any point on the underside of the vehicle except the tyres, wheels and wheel hubs. It should not be less than 1/20th of the distance between adjacent axles under any loading conditions.

The machine should be positioned where possible on the carrying vehicle's platform so that forward movement is prevented either by part of the main body of the vehicle (eg gooseneck step or headboard) or by an attached transverse member securely attached through the platform to the vehicle's chassis frame.

All items such as buckets, grabs, blades, shovels and lifting appliances should be removed from the superstructure or chassis and secured to the deck of the vehicle.

Wheeled and light-tracked machines should be restrained so that the effect of bouncing caused by road shocks transmitted from the carrying vehicle and amplified by the machine's tyres or suspension units is minimised. Where possible, the suspension unit of the machine should be locked and vertical movement limited by lashings or other means of restraint.

Where possible the full contact area of the equipment's tyres, tracks or rolls should rest on the platform or extensions to the platform of the carrying vehicle.

All the wheels or rolls of the machine should be prevented from rolling or sliding relative to the deck of the vehicle.

The machine should be restrained against forward, backward or sideways movement by adjustable restraining devices attached to anchor points on the vehicle.

The overall height of the loaded vehicle should be checked before it is driven on the road. Although correctly stowed, the machine's overall height may have changed since last transported through changing positions of its components, eg repositioning of pivot pin positions. It is also possible that a different vehicle will have a different platform height.

With the engine turned off, the pressure in a machine's hydraulic system should be relieved by moving all control levers through all positions when the machine is stowed. This operation should be done at least twice. Exhaust stacks should be capped for turbo charger protection.

### ***Anchor points on the vehicle***

The principles to follow when deciding on the strength, number and position of anchor points to be fitted to a vehicle are as described more fully in the strength requirements of restraint systems section (pages 14-17). The anchor points should be fixed securely to metal members of the chassis or cross members and should be capable of transmitting all the forces imposed on them to the main chassis frame of the vehicle.

Each anchor point should be capable of withstanding a force equal to the lashings being used, acting in any direction through which the lashing can

be attached. In deciding the number of anchor points to be used when devising a restraint system, the following factors should be considered:

- The need to position the machine to achieve the correct load distribution to meet the axle load requirements and to ensure that the vehicle's handling is not impaired.
- The extent to which other load restraint features are incorporated in the design of the vehicle.
- Whether the machine has wheels, tracks or rolls.
- The mass of the machine to be carried.

Unless loaded on a special purpose vehicle, there should never be less than four anchor points used, ie two per side.

The lashings or securing devices should only be attached to those parts of the engineering plant that are compatible in strength with the vehicle's anchorage points. They should not be attached to any part of the machine being carried where there is a risk that damage can be caused when the vehicle is moving, eg a draw bar provides an ideal anchor point. When suitable anchor points are not readily available on a machine, it is recommended that special additional anchor points be provided (see the following illustrated examples). It is also recommended that, when purchasing new machines, suitable anchor points should be included before accepting delivery of the machine.

### *Restraining devices*

Apart from specialised fixing devices, the selection of material for use in tie-down schemes for construction equipment will be limited to chains, steel wire rope and the associated tensioning and coupling devices. Ensure the size is matched to the mass of the payload.

The strength of the lashing should be compatible with the strength of the anchor points used and its selection should be based on the restraint principles (see pages 14-17).

Where a transverse beam is used as a baulk, it should be securely fixed so that all loads imposed on it are transmitted to the carrying vehicle's chassis frame. Where individual wheels or rolls are chocked with blocks or wedges these must be robust enough to resist crushing and be securely attached to the vehicle's platform where possible.

Load pegs may be fitted along each side of the vehicle to prevent transverse movement, particularly on tracked vehicles (see following examples). The lashings or securing devices should only be attached to those parts of the construction equipment which are compatible in strength with the vehicle's anchorage points. They should not be attached to any part of the machine where

there is a risk that damage can be caused when the vehicle is in motion. It is important to ensure that lashings that provide front and back restraint are as near to the horizontal as possible and never more than 60° from the horizontal. This is because the stress in the lashing rises very sharply as the angle approaches the vertical and failure can occur. A chain that is placed at 60° to the horizontal provides a front or back restraining force equal to ½ the chain's rated strength. If the chain is placed at 60° to the horizontal and 60° across the vehicle, its strength is reduced to ¼.

## **SUGGESTED METHODS FOR RESTRAINING MACHINES**

Recommended methods for restraining particular types of construction equipment and precautions to be taken are illustrated on the following pages. Variations of these methods are acceptable provided all the basic safety precautions outlined previously in the section have been applied.

On machines with articulated steering, articulation of the front part of the machine relative to the rear part should be prevented by fitting a locking device. You must relieve hydraulic pressure in the system by operating all controls twice with the engine off.

### ***Rubber tyred crane - rough terrain***

**Hazard 1** – Height of the crane.

Precaution: Check the route. Ensure minimum clearance available exceeds maximum overall height of crane mounted on a low loader.

**Hazard 2** – Movement of the boom and superstructure relative to chassis of machine.

Precaution: Relieve the hydraulic pressure by operating the controls twice, with the engine off where possible. Engage slew lock if fitted, and if none fitted provide an independent restraint to prevent slewing motion.

**Hazard 3** – Forward and rearward movement of the crane.

Precaution: Restrain with chains and tensioners at front and rear of the crane.

**Hazard 4** – Sideways movement of the crane.

Precaution: Restrain with chains and tensioners on each side.

**Note:** Where cranes are to be transported considerable distances or over rough roads, it is recommended that the weight be removed off the tyres to prevent 'bounce' effects that are induced by road surface irregularities and large pneumatic tyres. Under severe conditions this bounce may snap restraining chains.

This can be achieved using the outriggers to lift the crane, taking the majority of the weight off the tyres. Large wooden blocks must then be packed between the low loader deck and outrigger beams. The outriggers must then be fully retracted in both vertical and horizontal positions. Chains and tensioners can then be applied to restrain the crane.

## Tractor dozers

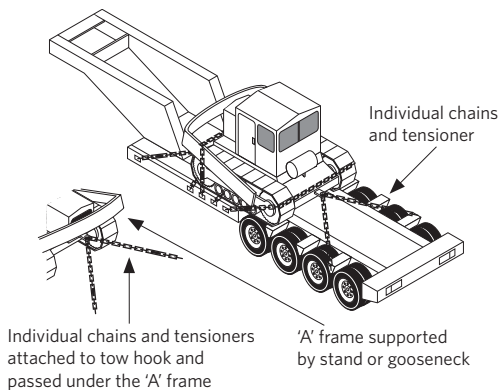


Figure 38 Suggested method of restraining a tractor dozer

### Hazard 1 - Height of the machine.

Precaution: Check the route, determine the minimum clearance available. If necessary remove the canopy, exhaust pipe or any component exceeding the limit.

### Hazard 2 - Width of the machine.

Precaution: Check the overall width of the machine is within the legal limits or conditions of an overdimension permit. 'A' frame and/or dozer blade may have to be removed. Depending upon axle loads and space available, these components may have to be transported separately.

### Hazard 3 - Forward or rearward movement.

Precaution: Restrain with a pair of individual chains and tensioners at the front and rear of tractor dozer. Suggested anchor points on tractor dozer - drawbar at rear and tow hook in front.

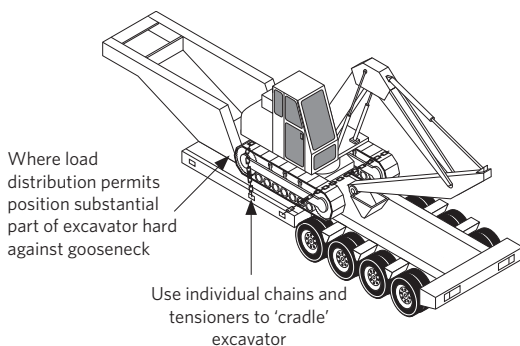
### Hazard 4 - Sideways movement of the machine.

Precaution: Restrain with a chain and tensioner on each side. Locate the chain behind carrier roller brackets. Desirable maximum length of chain is 4 metres.

**Hazard 5** – Movement of items removed from the tractor dozer.

Precaution: Restrain dozer blade, 'A' frame, side arms, etc with independent individual lengths of chain no longer than absolutely necessary. Locate chains to provide as direct a tension as possible and to prevent movement forward, rearward or sideways.

### *Hydraulic excavator (crawler mounted)*



**Figure 39** Suggested method of restraining a hydraulic excavator (crawler mounted)

**Hazard 1** – Height of the machine.

Precaution: Check route – ensure the minimum clearance available exceeds the maximum overall height of the excavator mounted on low loader.

**Hazard 2** – Movement of the boom and superstructure relative to chassis of machine.

Precaution: Relieve hydraulic pressure by operating all controls twice, with the engine off where possible. Engage slew lock if fitted, and if none fitted provide an independent restraint to prevent slewing motion.

**Hazard 3** – Forward and rearward movement of the machine.

Precaution: Where load distribution permits, locate the rear of the excavator hard against gooseneck. Cradle the excavator in individual chains each tensioned with individual tensioners. Desirable maximum length of chains is 4 metres.

**Hazard 4** – Sideways movement of the machine.

Precaution: 'Cradle' chains provide restraint in this direction, also.

**Hazard 5** – Movement of buckets and attachments which are detached from the machine.

Precaution: Restrain with independent individual lengths of chain no longer than is necessary to prevent movement forwards, rearwards and sideways.

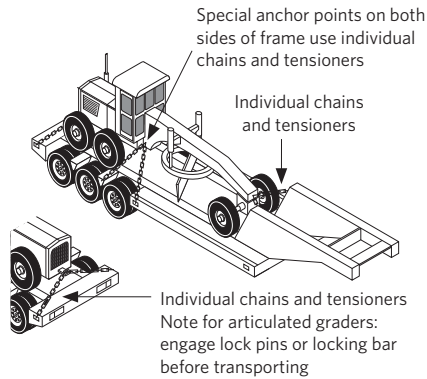


Figure 40 Suggested method of restraining a powergrader

### **Hazard 1** - Height of the grader.

Precaution: Check route, determine minimum clearance available. If necessary remove the canopy, exhaust pipe or any other component exceeding the limit.

### **Hazard 2** - Width of the grader.

Precaution: Angle the grader blade to reduce the overall width to within the legal limit, otherwise remove the blade.

### **Hazard 3** - Forward and rearward movement of the grader.

Precaution: Locate the front wheels or rear wheels against the gooseneck. Lower the blade onto the deck of the trailer. Restrain the grader at the front and rear. The drawbar and front axle bolster are ideal anchor points.

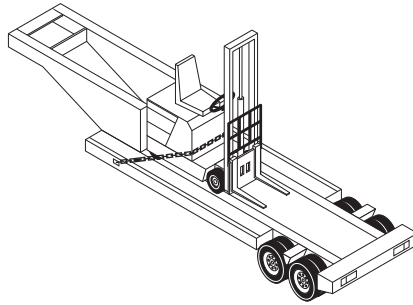
### **Hazard 4** - Sideways movement of the grader.

Precaution: Restrain with chains and tensioners on each side. Where necessary provide special anchor points on the grader frame to facilitate side restraint.

**Hazard 5** - Movement of the blade that has been detached from the grader, on graders with articulated steering, articulation of front part of machine relative to rear part.

Precaution: Restrain with independent individual lengths of chain. Prevent movement forward, rearward and sideways. Fit locking device to prevent articulation. Relieve the hydraulic pressure in the system by operating all controls twice with the engine off where possible.

## Fork lift truck



**Figure 41** Suggested method of restraining a fork lift truck

### **Hazard 1** - Height of the fork lift.

Precaution: Check the route and determine the minimum clearance available. Ensure the minimum clearance exceeds the maximum overall height of fork lift mounted on a low loader.

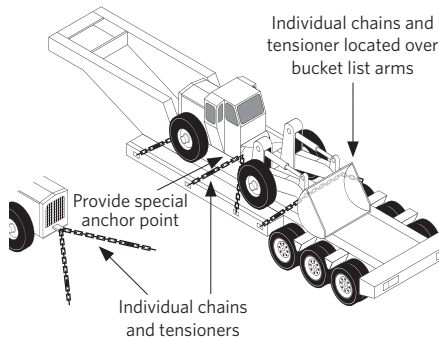
### **Hazard 2** - Forward and rearward movement of the fork lift.

Precaution: Where possible butt the rear of the fork lift (counterweight) hard against the gooseneck of the low loader. Restrain with a 'cradle' chain and tensioner. The desirable maximum length of chain is 4 metres. Lower the forks onto the deck of a low loader.

### **Hazard 3** - Sideways movement of the fork lift.

Precaution: A cradle chain provides restraint in this direction also.

## *Pneumatic tyred four-wheel drive loader*



**Figure 42** Suggested method of restraining a pneumatic tyred 4-wheel drive loader



**Hazard 1** - Height of the loader.

Precaution: Check the route. Determine the minimum clearance available. Ensure the minimum clearance exceeds the maximum overall height of the loader mounted on a low loader. Remove components exceeding the limit.

**Hazard 2** - On loaders with articulated steering. The articulation of the front part of machine is relative to the rear part.

Precaution: If equipped with slew lock, it must be used as a locking device, to prevent articulation. Relieve hydraulic pressure in system by operating all controls twice with the engine off where possible.

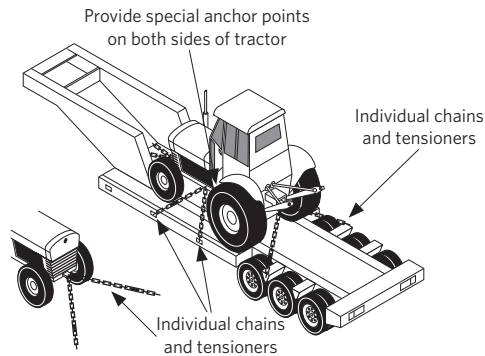
**Hazard 3** - Forward and rearward movement of the loader.

Precaution: Restrain at rear with individual chains and tensioners. The drawbar provides an ideal anchor point. At the front locate a chain and tensioner over the bucket lift arms. The desirable maximum length of chain is 4 metres.

**Hazard 4** - Sideways movement of the loader.

Precaution: Restrain with chains and tensioners on each side. Where necessary provide special anchor points on the loader frame to facilitate side restraint.

**Pneumatic tyred tractor**



**Figure 43** Suggested method of restraining a pneumatic tyred tractor

**Hazard 1** - Height of the tractor.

Precaution: Check the route. Determine the minimum clearance available. If necessary, remove any component exceeding the height limit.

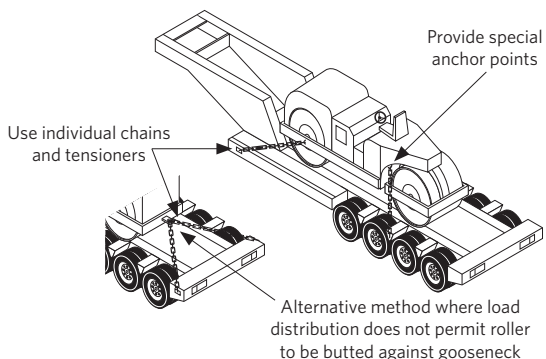
**Hazard 2** - Forward or rearward movement of the tractor.

Precaution: Restrain with pairs of individual chains and tensioners at the front and rear of the tractor. The drawbar is an ideal rear anchor point. Where the front axle is unsuitable as an anchor point it is recommended that special anchor points be provided on the main frame.

### Hazard 3 – Sideways movement of the tractor.

Precaution: Restrain with chains and tensioners on each side. Where necessary provide special anchor points on the tractor side frames to facilitate side restraint.

### *Steel wheeled roller*



**Figure 44** Suggested method of restraining a steel wheeled roller

### Hazard 1 – Height of the roller.

Precaution: Check the route. Determine the minimum clearance available. Remove any components exceeding the limit.

### Hazard 2 – Forward and rearward movement of the roller.

Precaution: Do not butt the front roll against the trailer gooseneck or restrain the front of the roller with chains attached to the front roll assembly as the front roll kingpin may be damaged. Where load distribution permits, butt the rear of the roller hard against the gooseneck and restrain with individual chains and tensioners to anchor points in the vicinity of the rear roll axle. Alternatively, locate the roller to meet the load distribution requirements and use drawbar as the rear anchor point. To restrain the front of the machine provide special anchor points and fit individual chains and tensioners.

### Hazard 3 – Sideways movement of the roller.

Precaution: This is restrained by chains used to control the forward and rearward movement.

## Dragline excavator

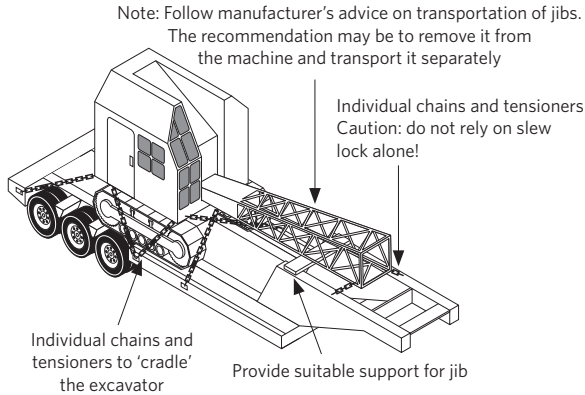


Figure 45 Suggested method of restraining a dragline

### Hazard 1 - Height of the dragline.

Precaution: Check the route. Ensure the minimum clearance available exceeds the overall height of the dragline mounted on a low loader.

### Hazard 2 - Width of the dragline.

Precaution: Check the overall width. Where the overall width exceeds the limit, a special permit should be obtained and any special conditions applicable rigidly applied.

### Hazard 3 - Length of the dragline.

Precaution: Check the dragline manufacturer's advice on transportation of the jib. If it is permissible to leave the jib or a section of it attached to the superstructure during transit, check that the extreme end of the jib does not, wherever possible, overhang the front or rear of the low loader (trailer) increasing the swept path of the combination.

### Hazard 4 - Movement of the boom and superstructure relative to chassis of machine.

Precaution: Engage a slew lock if fitted. If none are fitted, provide an independent restraint to prevent slewing motion.

### Hazard 5 - Forward and rearward movement of the machine.

Precaution: Where load distribution permits, locate the dragline tracks against the gooseneck. 'Cradle' the machine in individual chains each tensioned with individual tensioners. The desirable maximum length of chains is 4 metres.

**Hazard 6** – Sideways movement of the dragline.

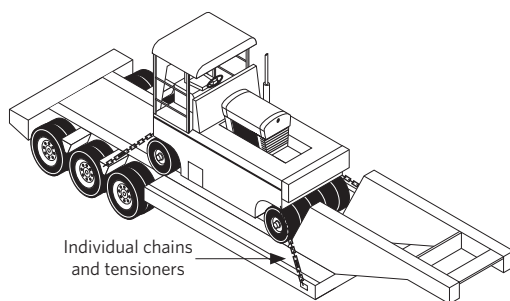
Precaution: 'Cradle' chains provide restraint in this direction also.

**Hazard 7** – Movement of buckets and attachments which are detached from the machine.

Precaution: Restrain with independent individual chain lengths. These should be no longer than are necessary to prevent forward, rearward and sideways movement.

**Note:** Follow the manufacturer's advice on transportation of jibs. The recommendation may be to remove it from the machine and transport it separately.

### *Pneumatic tyred roller*



**Figure 46** Suggested method of restraining a pneumatic tyred roller

**Hazard 1** – Height of the roller.

Precaution: Check the route. Ensure the minimum clearance available does not exceed the limit. If necessary remove the canopy, exhaust pipe, air cleaner or any other component exceeding the limit.

**Hazard 2** – Forward and rearward movement of the roller.

Precaution: Restrain with individual chains and tensioners positioned on four corners of the body.

**Hazard 3** – Sideways movement of the roller.

Precaution: Restrained by chains used to control the forward and rearward movement.

# Timber loads

The sawn timber and logging sections of this code include the relevant parts of the Department of Labour codes, which have been based on a joint industry and government department group that has researched and proved the safety needs. The style of this section is slightly different from the rest of the code as it has been written by the Department of Labour. Some sections that are not relevant to road transport have been omitted.

## LOGS

Refer to the Log Transport Safety Council log loading code.

For more information contact:

The Secretary  
Log Transport Safety Council  
127 Balmoral Drive  
Tokoroa

Email: [tgmsservices@xtra.co.nz](mailto:tgmsservices@xtra.co.nz)

Website: [www.logtruck.co.nz](http://www.logtruck.co.nz)

## SAWN TIMBER

Increasing amounts of timber are being transported on public highways on vehicles which are constantly increasing in size and payload capacity. Government and industry are concerned at the number of fatal and serious accidents involving the collapse of timber stacks and the spillage of loads of timber in transport.

This section has been prepared following several years of research and investigations, plus extensive tests, to publicise what has been proven to be the safest and most correct methods of securing timber on vehicles in preparation for transportation.

The tests and investigations have also shown the need for correct design requirements for the vehicles and restraint equipment, as well as for minimum standard methods for securing a load on a vehicle.

### *Design requirements*

#### **RESTRAINING THE LOAD**

Any load carried on a vehicle must be sufficiently restrained to prevent movement from forces which arise from the vehicle passing over road undulations, when it changes direction, or when it is being braked or accelerated.

The forces involved in restraining the load in braking depend on the deceleration and the weight of the load, and are not dependent on the speed of the vehicle. If, however, a load does move at high speed, it will have more energy and hence it will cause more damage.

It requires much more force to stop a load which has started moving than it does to prevent the movement in the first place. It is essential, therefore, that the vehicle is loaded and the load restrained in such a way that no part of the load can freely move in any direction.

The total restraint required to accommodate the forces which arise will generally be obtained from a combination of the following:

- Securing devices, such as chains fixed to anchor points and suitably tensioned.
- Restraining arrangements, such as headboards and side posts.
- Friction between the load and the vehicle platform.

A load carried on a vehicle without restraining devices will not be secure because the frictional restraint between the load and the platform of the vehicle will be less than the dynamic forces which tend to move the load. It follows, therefore, that it is necessary to provide additional restraint to prevent the load moving.

### **RESTRAINT REQUIREMENTS**

The load restraint system must be capable of preventing movement of the load under three particular conditions (see figure 47):

- 1 Forward deceleration under emergency braking conditions, when the combined restraining forces must be at least equal to the total payload weight.
- 2 Rearward deceleration when braking during reversing, when the combined restraining forces must be at least 50 percent of the payload weight.
- 3 Sideways or lateral acceleration when cornering, when the combined restraining forces must be at least 50 percent of the total payload weight.

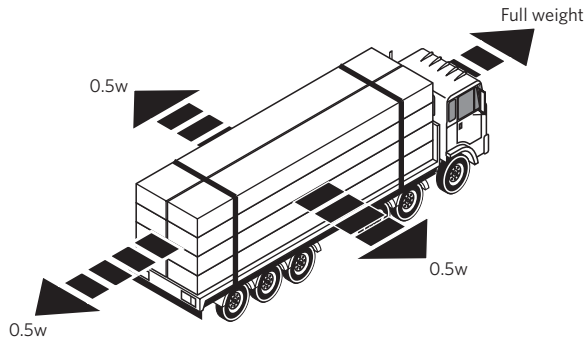


Figure 47 Payload forces

The load restraint system must be able to withstand:

- the full weight of the load forwards
- half the weight of the load sideways
- half the weight of the load backwards
- one-fifth of the weight of the load vertically upwards.

In certain circumstances, vertical acceleration may occur but this will be overcome if the restraints mentioned above are imposed by lashings placed over the load.

### Vehicle requirements

In addition to meeting the statutory requirements applicable to the construction, equipment and loading of motor vehicles, the vehicle's load space and the condition of the platform must be suitable for the type and size of the load to be carried. The manufacturer's gross vehicle weight must not be exceeded; nor should the individual axle weight be exceeded.

Unless the requirements for packages loaded without a headboard (see page 75) are fully met, either a headboard or cab guard must be fitted between the load and the cab.

### TRANSPORTATION ON AN OPEN PLATFORM

The following is specifically related to transportation using securing devices and an open loading platform. Any other load restraint system must be certified by a person approved to undertake certification in accordance with NZS 5444 *Load anchorage points for vehicles*.

A minimum of two securing devices must be used to secure each section of load. When a third device is required, it should be passed over the lower half of the load only. Subsequent devices should be over the complete load.

Care must be taken to ensure that the securing devices are placed at points where the load is rigid, extending over the load to anchor points opposite each other.

Securing devices should be tightened at the start of a journey, checked after a few kilometres of travel, and then rechecked during the course of the journey as the timber settles on the vehicle. Steel corners help to protect the load and reduce slackening as the securing device cuts into the timber.

Uneven ends should, where possible, be at the rear of the vehicle. Any loose ends of timber should be secured, pulling them together to minimise whip.

When packets are not the total width of the truck deck, spacers should be placed in the centre of the load to extend the load widthways to get maximum effect from the securing system and minimise sideways movement of the load.

A slippery platform surface is always dangerous. The aim should be to obtain the maximum advantage from frictional restraint by keeping both the base of the load and the platform surface as clean, dry and free from grease as possible.

When the load is wrapped, timber bearers should be used to minimise movement on steel decks.

## *Restraint equipment*

### **HEADBOARD**

A headboard, when fitted to the front of the platform of a vehicle, must be capable of withstanding a horizontal force uniformly distributed over the vertical area, equal to half the rated payload capacity of the vehicle. Where possible, the load should be placed tightly against the headboards. If this is not possible, additional packing or chocks should be placed between the load and the headboard.

The headboard should meet with the following requirements:

- The width should be at least equal to the width of the cab, and should be equal to the width of the loading platform.
- The height should be at least equal to the height of the cab.

### **CAB GUARD**

A cab guard must be designed to protect the driver in the event of a rollover and also to absorb the impact of a load moving forward.



## **SIDEBOARDS AND TAIL GATES**

Sideboards and tail gates, when fitted to the rear or the side of the vehicle platform and used as load restraint equipment, must be capable of withstanding a horizontal force uniformly distributed over the vertical area. The force must be equal to half the total payload weight.

## **SIDE AND CENTRE POSTS**

Side and centre posts, when fitted and used as load restraint equipment, must be capable of withstanding a horizontal force uniformly distributed over the vertical area. As above, the force should be equal to half the total payload weight. Side posts must be arranged or braced so that the width of the vehicle when laden does not exceed legal limits. All posts must be designed so that they cannot inadvertently become detached from the holders.

## **LOAD ANCHORAGE POINTS**

Load anchorage points must comply with the requirements of NZS 5444 *Load anchorage points for vehicles*. The number of anchorage points fitted and used and their strength must be equal to the securing device being used, and should be at least as strong as the securing device. For example, if two 5-tonne-rated strength securing devices are used, the four anchor points must each have a strength of 5 tonnes.

## **SECURING DEVICES**

The securing device and the tensioning device must be maintained in a sound condition. Over-tensioning should be avoided as this could overload the system and weaken it.

## **TARPAULINS**

Sheets or tarpaulins should be regarded as providing no more than weather protection. The load must be independently restrained against movement.

## **ROPE OR CORDAGE**

Sisal and manila ropes should be used only for securing tarpaulins or loads of less than 0.5 tonne. These ropes are easily damaged and constant examination is required to ensure they are serviceable.

Other ropes should comply with AS/NZS 4345. Preferred ropes are of polypropylene, polyester or polyamide manufacture.

When purchasing, the buyer should ensure the supplier gives written information about the ropes and the standards to which they have been made. This would include the types of material and construction, the minimum breaking force and the standard number.

Avoid contact with chemicals, oils and paints. Provide a suitable box for storage. To extend the rope's life, coil with the lay and avoid excessive knotting, sharp bends, chafing and passing over sharp or rough edges.

Regular detailed examination for wear and mechanical damage should be carried out. If there is any doubt about the ability of the rope to perform safely, it should be withdrawn from service.

## **CHAINS**

All chains must be of short link and comply with AS/NZS 4344 or BS 4942. Tensioning devices and fittings, which must be identified with manufacturer's identity and rated load, must be compatible in size and strength with the chain to which they are attached. All manufacturers and importers of tensioning devices and fittings to be used with such chain must ensure that components carry an SWL identification.

The following safety precautions must be taken when using and inspecting chains:

- Chains securing loads must be tightened, the tensioning device securely locked, all loose ends secured and all securing requirements met prior to the vehicle commencing its journey. The load should be checked at intervals during the journey.
- Care must be taken to ensure that the chains and other devices are handled with regard to the safety of the user and other persons in the vicinity.
- Chains must extend over the load, with each end attached to anchor points approximately opposite each other. The number of chains must be sufficient to ensure the proper securement of all loading of the vehicle in accordance with the weight distribution of the load and the location and strength of anchor points.
- Chains must be secured to anchor points by either a permanent attachment or a suitable chain coupler. No chain must ever be knotted.
- Care should be exercised not to overstrain chain systems.
- Chain systems and anchor points must be maintained in good condition. Chains or other components must be replaced if they show any of the following conditions:
  - Cracked welds or links in chains or load binder attachments.
  - Bent, twisted, stretched or collapsed links.
  - Gouges or pits in links, hooks, etc reducing the diameter by 10 percent or more.
  - Chains repaired or joined by repair links of a type other than those designed for the purpose.

- Links, hooks, etc obviously worn and showing other visible evidence of loss of strength (wear 10 percent or more).
- Knots in any portion of the chain.
- Spread or distorted hooks.
- Anchor points used in the securement of the load which are in a weakened condition or show evidence of loss of strength because of cracks, breaks, distortion or other deterioration. Chains and hooks must not be repaired by welding.

Claw hooks are preferable to grab hooks, as grab hooks reduce chain strength by approximately 25 percent.

### WEBBING

All webbing load restraint assemblies must comply with AS/NZS 4380.

Webbings, winches and fittings must be maintained in good condition and used in accordance with the manufacturer's instructions. Webbing must be replaced if there is any sign of damage, chafing, fraying or stitching failure. Fittings, winches, etc must be replaced if bent, worn or faulty and must not be repaired by welding.

## Timber stacking and packeting

### STACKING TIMBER

The methods used for stacking and packeting timber depends on its end use and destination. Large quantities of timber are fillet stacked for both kiln and air drying. Under normal conditions, timber for air drying can remain for up to one year in this state. When kiln drying, the period is usually of shorter duration. When timber is to be stacked for any considerable period of time, the stacks must be monitored by the yard proprietor or designated agent to ensure their continued stability.

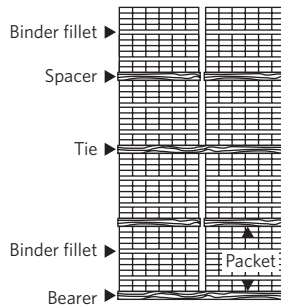


Figure 48 Parts of a timber stack

The movement and stacking of timber must be carried out in accordance with the Department of Labour's *Safety code for forklift operators, The approved code of practice for training operators and instructors of powered industrial lift trucks (forklifts)*. Part 1: Front loading forklift trucks and Part 2: Straddle trucks. Particular attention should be given to section 5.5, Part 1, which states:

'Only carry loads that are supported by their carriage or backrest extension.'

Figure 48 illustrates the parts of a timber stack. The rule is the height is to be no more than four times the width of the base. If it is intended to exceed this, a tie is required.

### **STACKING AND SECURING TIMBER IN THE OPEN**

Before allowing stacks to be constructed in the open, a check must be made by the yard proprietor or designated agent to determine if the ground is firm enough to support any load expected to be placed there. The existence of drains, water pipes or electric supply mains under the proposed site must be ascertained. Manholes, stop valves, cable chambers and fire hydrants must not be built over. When timber is stacked adjacent to a boundary where there is public access, the stacks should be end on, at least 1 metre from the boundary. Alternatively, if stacked side on to the boundary, then restraining devices of calculated strength must be provided to the full height of the stack.

The site for timber stacks should be selected for its ground stability, level and even contour, and its accessibility for whatever method is used to pile or unpile the stacks, for instance forklifts, side-loaders, hand stacking.

Solid foundations must be provided, otherwise the stack will be faulty from the start. The following types of foundation are acceptable:

- **Concrete** – The foundation should consist of closely spaced piles down to solid ground, or a solid concrete wall reinforced with steel.
- **Wood** – The foundations should be constructed of sound timber down to solid ground. Broken, damaged or decayed timber must be replaced.

Stack bearers or foundations should be placed as evenly as possible, and must be of an appropriate strength and size for the weight of the timber likely to be supported and to prevent sagging of the base packet.

Stacks should not be located too close to live power lines. You must ensure that machines which work the stacks are no closer than 4 metres to any live power lines.

Even a relatively light wind can dislodge timber from a stack in the open. The timber often has sufficient weight and falls far enough to kill or cause serious injury.

Upper layers of stacks exposed to high winds should be restrained to prevent dislodgement. Generally, stacks should slope slightly along their length so that rain water will run off.

While tarpaulins can be used to protect timber from the weather, they should not be used as a means of securing the stack.

### **STACK CONSTRUCTION**

The key to good stack building lies in the use of fillets, which tie adjacent pieces together by friction. Those used to stabilise block-stacked packets are called binder fillets. Those used to separate timber for drying are separation fillets.

Ties are equally important with stacks of packaged timber in that they stabilise adjacent packages and stacks.

Staggered plank ends protruding from stacks encourage people to use them for climbing and should be avoided where practicable.

No one should climb up the side or ends of any timber stack. A ladder should be used to facilitate stocktaking. Where a forklift is used for this purpose, a proper working platform must be provided.

### **FILLETING TIMBER**

All timber should be filleted and stacked with its greater dimension on the flat, and all fillets must be of even thickness.

Fillets and spacers should be long enough for the width of the stack. Should shorter ones need to be used, they must not be placed end to end but must overlap each other so that at least two tiers of timber are supported on each side of the overlap.

Wherever possible, fillets should not be left protruding more than 50mm beyond the edges of a stack to prevent danger to passersby.

Fillets must be placed immediately above each other and also in relation to the stack bearers. In general, the narrower the dimension of the timber, the wider and/or more closely spaced the fillets should be. They should never be placed over 1 metre apart.

When complete packets are piled one on the other, any irregularity or unevenness such as sagging ends must be corrected by packing with spacers that are placed between the packets.

### **PACKETING TIMBER**

The major cause of timber spillage has been the collapse of the base of the packets, where extreme force has been imposed on the load restraint devices. As all types of packet binders are tensioned from the top and do not effectively

consolidate the base, it is extremely important that when packets are being assembled and bound, the bottom layers are mauled up tightly.

The use and placement of binder fillets are important factors in creating a stable packet. Generally, they should never be more than 1 metre apart along the length of the packet. However, where an automated fillet system is used, a maximum spacing of 1.2 metres is allowable. Details of fillet position for various dimensions of timber are shown in figures 49, 50, 51 and 52.

As with filleting timber, packeting timber spaces should be long enough and should not protrude more than 50mm beyond the packet. The packets should be placed immediately above each other in relation to stack bearers.

All timber is to be packeted with its greater dimension on the flat.

Packets of random-length timber should be formed so that the short lengths are securely housed within the body of the packet. All outside pieces must engage all of the fillets. Where short lengths are butted, extra care must be taken to ensure that they remain secure.

### **BINDING PACKETS**

All packets of block-stacked timber must be suitably bound at a point as near as possible to where they have been assembled. For transporting short distances on level ground about a timber yard to treatment plants, planing sheds or filleting bays, it is not considered necessary to bind the packets as effectively as for when they are to be transported greater distances and on public roads.

All binders must be set square to the packet. Some packets will need to be rebound after drying, etc should binders be found to have lost their tension.

### **BINDING PACKETS FOR TRANSPORTATION**

Packets to be transported must be tightly put together, particularly at the base, and are to be bound with at least two strategically placed binders of equal or greater strength than 10-gauge 3.2 high-tensile wire, with a breaking strain of 661kg, suitably tensioned and secured.

Packets must be constructed and bound so they are able to withstand a horizontal acceleration equivalent to half the weight of the packet. If there is any doubt concerning this capability, then a simple tilt test can be carried out. The packet should be able to withstand a sideways tilt angle of at least 26° before showing signs of any significant distortion.

### **BLOCK STACKING OF PACKETS**

Generally, block stacking consists of placing packets of timber already prepared one on the other.

Because fewer fillets are used to provide binding of the stack and to compensate for irregularities, block stacking must never be higher than four times the width of the base. Where narrow packets are involved, they can be bound together to make one packet and then be stacked to four times the base width. This will help to retain storage capacity.

However, in storage sheds or where overhead cranes are used, packets can be stacked to 9.7 metres, provided a method of ensuring stability is used.

Packets stacked must be compatible in size and structure. Packets of long length timber must not be stacked on top of single short-length packets. Any sag in packets should be corrected by the packing of the spacers between the packets.

### **BREAKING DOWN STACKS AND PACKETS**

If more than one person is concerned in this operation, only one should be responsible for the manner in which the stack is reduced.

Binders must not be cut unless everyone is in a position of safety in case any part of the stack collapses or part of the binder flies back.

Binders must not be cut by any person standing on a stack unless it is adequately supported on both sides.

If it seems apparent that any part of a stack or packet will collapse when the binder is cut, the packet must be suitably stayed or held together by a forklift or other means.

The packet should be taken down layer by layer rather than tier by tier ensuring that the remaining part is in a safe condition.

Fillets, spacers, wires and straps, etc should not be left lying about as a tripping hazard.

### **MAXIMUM SIZES OF PACKETS FOR TRANSPORTATION**

Maximum sizes of packets for transportation are shown in figures 49–52.

l = length  
 w = width  
 h = height

f1 = bottom fillet height  
 f2 = subsequent fillet height

Note: the larger the cross section of the timber, the wider apart fillets can be placed

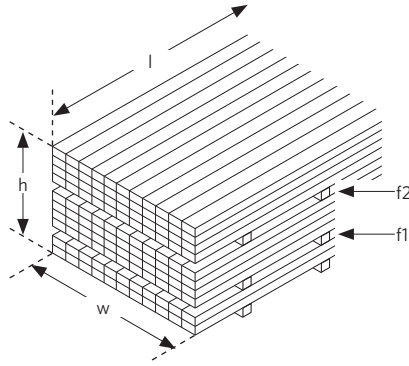


Figure 49 A typical packet of timber

l = any length  
 h = 600mm max  
 f1 = 100mm  
 f2 = 200mm

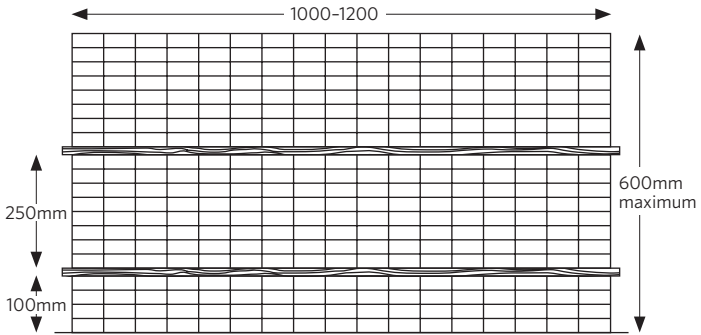


Figure 50 Placement of fillets for timber width less than 76mm

l = any length  
 w = 1.0-1.2 metres  
 h = 760mm max\*

f1 = 150mm  
 f2 = 300mm

\* For heights in excess of these values, the packet shall be bound to form a main packet and additional height strapped or wired to this main packet

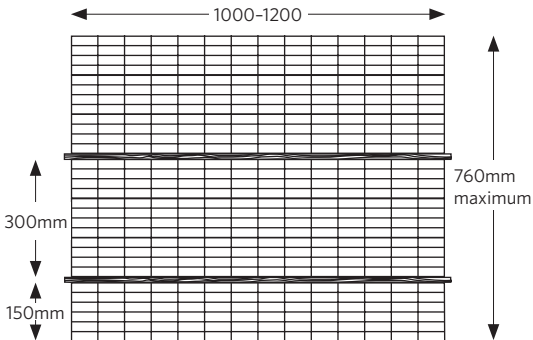


Figure 51 Placement of fillets for timber between 76mm and 125mm



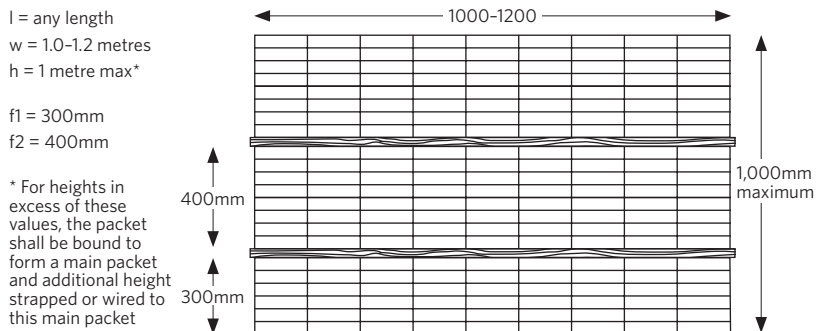


Figure 52 Placement of fillets for timber width greater than 125mm

## PACKETING OTHER WOOD-BASED PRODUCTS AND NON-STANDARD TIMBERPACKETS

It is difficult to identify all the different types and sizes of product under this title so it is understood that, in all cases, the spirit and intention of the preceding items in this code is followed by all concerned. Some of the more usual products are dealt with in the following paragraphs.

### ***Export packets of timber***

The sizes of export packets of timber are determined by shipping and the requirements of the overseas buyer. These are too numerous to describe, however the spirit of sound packaging as set out on page 69 applies.

Typical sheet wood products like plywood, particle board, veneer boards and hardboard, for example, are usually 2400 × 1200 (some at 3600 × 1800).

### ***Packets***

Figures 53 and 54 are typical examples of a small packet and a large packet.

l = 2,400mm  
w = 1,200mm  
h = 560mm

weight = 0.9 tonne

Securement of the packet would typically be by metal straps across the width as shown

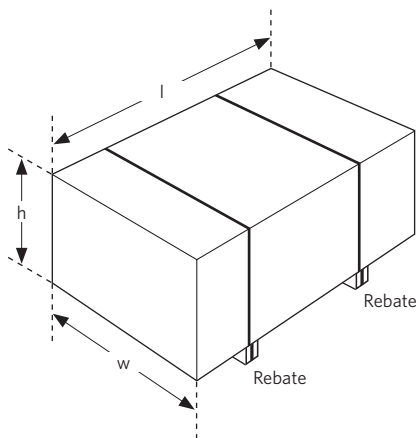


Figure 53 Typical small packet

l = 2,400mm  
w = 1,200mm  
h = 1,000mm

weight = 1.5 tonne

If bearers are to be an integral part of the packet, longitudinal straps shall be secured (and not passed around the bearers) before the rebated straps are secured

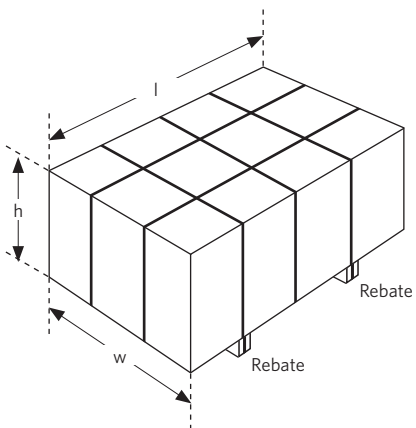
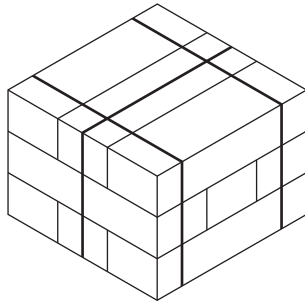


Figure 54 Typical large packet



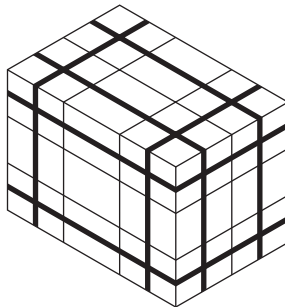
**Figure 55** Cross stacking and interlocking

### ***Decorative boards***

Decorative boards that are slippery by nature should be encased in 7.5mm plywood or shrunken heavy-duty polythene before being secured with straps or wire. For convenience and minimal damage, bearers may be incorporated with the packet.

### ***Small-piece timber products***

Small-piece timber must be packeted so that under normal circumstances stacks and packets are self-supporting. Full use of cross-stacking and interlocking techniques should be made (see figure 55). Some packets may need binding in three directions (see figure 56).



**Figure 56** Three-dimensional binding

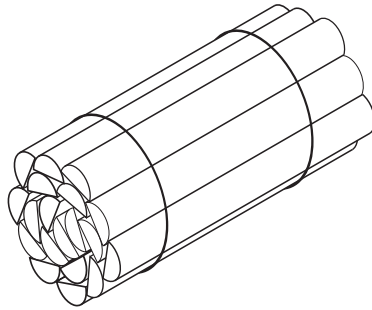


Figure 57 Half-round posts

## Standard methods

### SECURING DEVICES FOR PACKETS

Packets of timber meeting the timber stacking and packeting requirements (see pages 66-75), which are to be transported on a vehicle platform, must be secured by securing devices which pass from the deck on one side of the vehicle over the load to the anchor point on the other side of the deck.

For packets which are not loaded against a headboard, the securing devices must have a combined rated strength of at least twice the weight secured, eg a 10 tonne payload will require two chains, each having a rated strength of 10 tonnes (see figure 58).

For packets which are loaded against a headboard (see page 63) so that the tops are supported by at least 150mm, the securing devices must have a combined rated strength of at least the payload secured, eg a 10 tonne payload will require two chains each having a rated strength of 5 tonnes (see figure 59).

For packets which are loaded so that the lower packets are supported by a headboard (see page 63), but the upper packets are not supported, must be secured by securing devices, having a combined strength of at least 1.5 times the payload secured, eg a 10 tonne payload will require two chains each having a rated strength of 7.5 tonnes (see figure 60).

### ADDITIONAL REQUIREMENTS FOR NON-PACKETED TIMBER

Timber or other timber products, which are not packaged according to the requirements set out in pages 66-72, must be transported as if they were packeted timber. However, suitable centre or side posts must also be used.

### EXAMPLE OF CHAINS FOR SECURING A 10-TONNE PAYLOAD

8mm grade P chain rated strength = 5.12 tonnes

10mm grade P chain rated strength = 8.0 tonnes

8mm PWB Hi-65 chain rated strength = 7.1 tonnes

If the load is against the headboard, chains of 10 tonne rated strength are required. For example:

- 2 × 8mm grade P chains, or
- 2 × 10mm grade P chains, or
- 2 × 8mm Hi-65 chains.

If the load is not against the headboard, chains of 20 tonne rated strength are required:

- 4 × 8mm grade P chains, or
- 3 × 10mm grade P chains, or
- 3 × 8mm Hi-65 chains.

Not loaded against headboard.  
Combined rated strength of at least twice the weight secured.

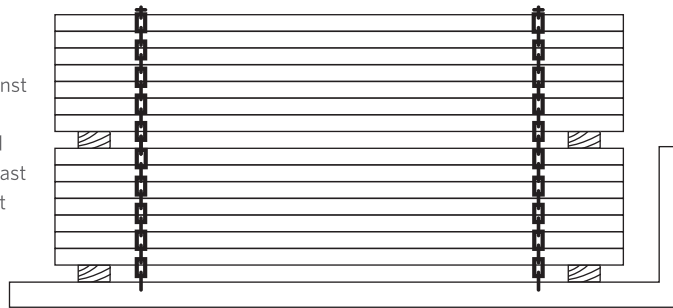


Figure 58 Packets not loaded against a headboard

Bottom packet against headboard and top packet supported by at least 150mm.  
Combined rated strength of at least the payload secured.

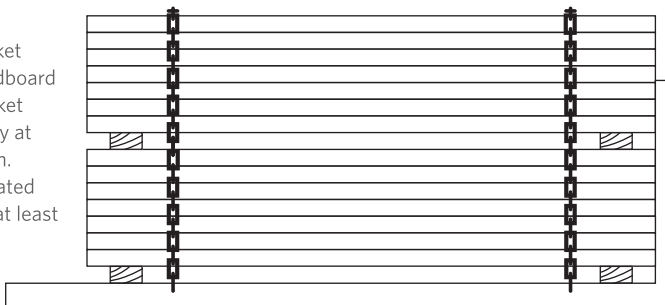
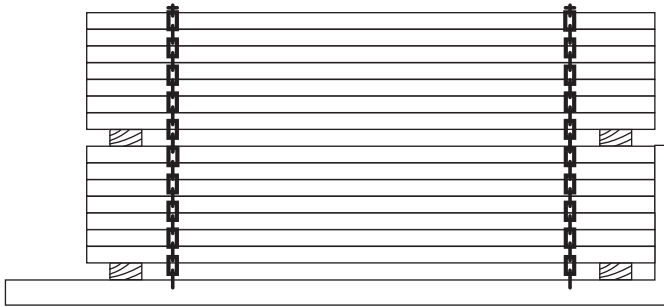
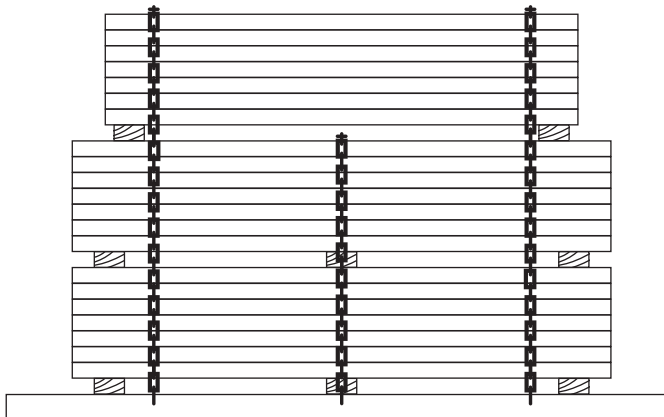


Figure 59 Packets loaded against a headboard



**Figure 60** Bottom packets against headboard but upper packet not secured



**Figure 61** Method of securing with three chains

In all circumstances the driver of any truck and trailer carrying sawn timber has the final responsibility to ensure that the truck is loaded correctly. The driver is also responsible for the correct securing of the load in accordance with this code and the Department of Labour's *Approved code of practice for safety and health in forest operation*, Part 5, Timber stacking, packeting and transportation.

# Steel products

This section is intended to provide guidance on the measures necessary to ensure safe carriage of metal loads. Although these take many forms, they can be divided into the following broad categories:

- Metal plate and flat sheets.
- Metal sheet in rolls (coils).
- Metal bars or billets.
- Structural steel and pipes.
- Large castings and fabricated units.
- Wire coils.
- Scrap metal.
- Ingots.

Some types of light load, eg small castings, may be carried on sided vehicles and no additional restraint should be required if the sides of the vehicle are higher than the load. In general, however, additional means of restraint will be necessary. Where loads are carried which could apply localised forces, headboard and sideboards should be reinforced.

Certain general principles apply to all metal loads, and these are outlined below.

## LOADING ARRANGEMENT ON VEHICLE

The principles outlined on pages 8-13 will apply. In particular, the load should, whenever possible, be placed against the headboard, and evenly spread to keep the centre of gravity as low as possible. The load should be packed and lashed in such a way that no part can move in any direction independently.

The metal processor usually dictates the loading arrangement because the processor usually prepares each lift or coil for transport, eg by wrapping and strapping to appropriate pallets.

## RESTRAINING DEVICES

All vehicles used for steel cartage should have as part of their equipment a binder, pins and chains for the securing of all articles carried. Chains should be tightened by you before your vehicle leaves the loading area.

In general, chains and tensioners should be used to secure metal loads. The selection of lashing should be based on the principles set out on pages 8-13. Where ropes or webbing are used, particular care must be taken to avoid contact with sharp edges.

## **FRICTION**

The friction within the metal load will in general be low, particularly if the metal is greased. Friction should therefore be disregarded when methods of restraint are being decided. Suitable wooden chocks must be used to avoid, wherever possible, contact of the steel on the tray of a vehicle.

If the metal is strapped into units for ease of handling, the straps should be in good condition, and should be examined to ensure that they have not been damaged in transit or handling.

Flat rubber placed under and between lifts of clean dry sheet increases friction significantly and thereby improves longitudinal and lateral-restraint.

## **METAL PLATE**

For cut lengths carried lengthwise refer to figure 62. The load should, whenever possible, be placed against the headboard or baulking with short plates on top of the load and at the front so that they cannot slide forward. When the load consists of two or more lifts along the deck of the vehicle, if axle loading distribution allows, the lifts must be placed in contact, or spacers must be used to prevent the rearmost lift(s) sliding into the other(s). Where possible no lift should be higher than the one in front. Each lift must be restrained in a manner which complies with the principles set out in pages 8-13. Where the use of dunnage is unavoidable, it must comply with the conditions set out in pages 8-13 also, and must be positioned so as to prevent any whip in the load.

As shown in figure 62 each bundle of sheet should be restrained with a minimum of two chains and tensioners which are attached to substantial anchor points.

An unsupported section of rope rail cannot be used.

Adequate baulking spacers and protectors must be provided to prevent the load being damaged through contact with lashings. Unused conveyor belting and sections of tyres make excellent protectors.

For an example of cut lengths carried crosswise refer to figure 63. The principles applied are similar to those recommended for cut lengths of metal sheet transported lengthwise, with the addition of the adjustable plate restraints illustrated. Beams with adjustable pegs, in conjunction with the chains and tensioners, provide effective longitudinal and lateral restraint.



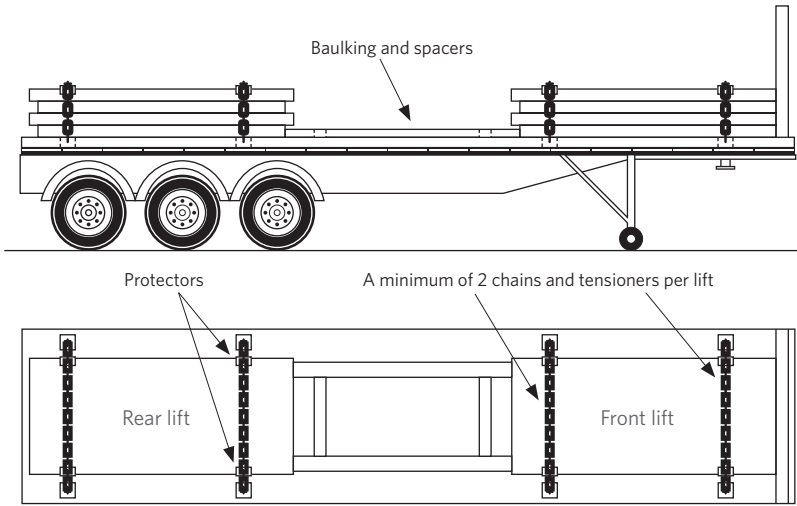


Figure 62 Metal sheet - cut length - lengthwise

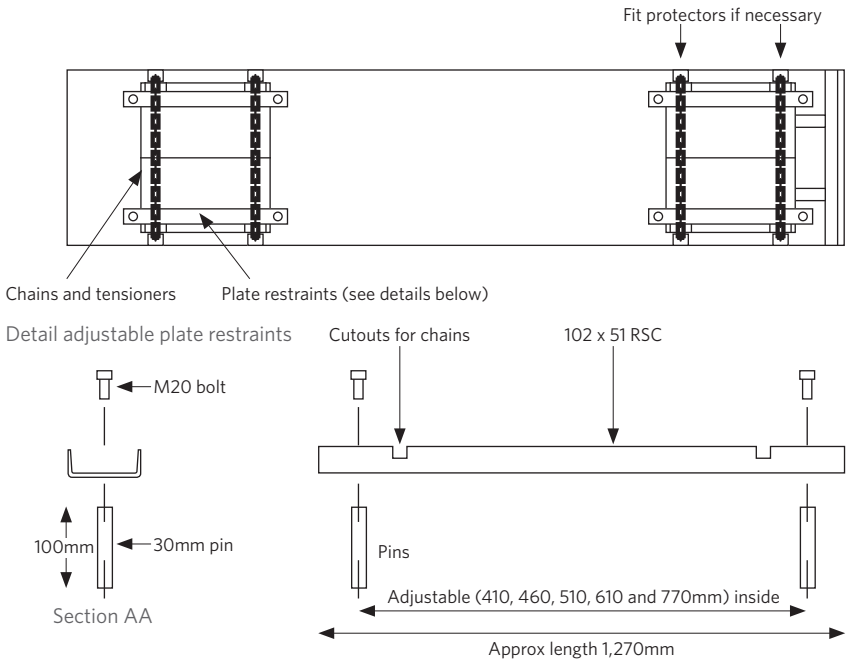


Figure 63 Sheet - cut length - crosswise

## SECURING OF METAL SHEET COILS OR ROLLS

Examine the deck strength to ensure it is adequate before loading steel coils.

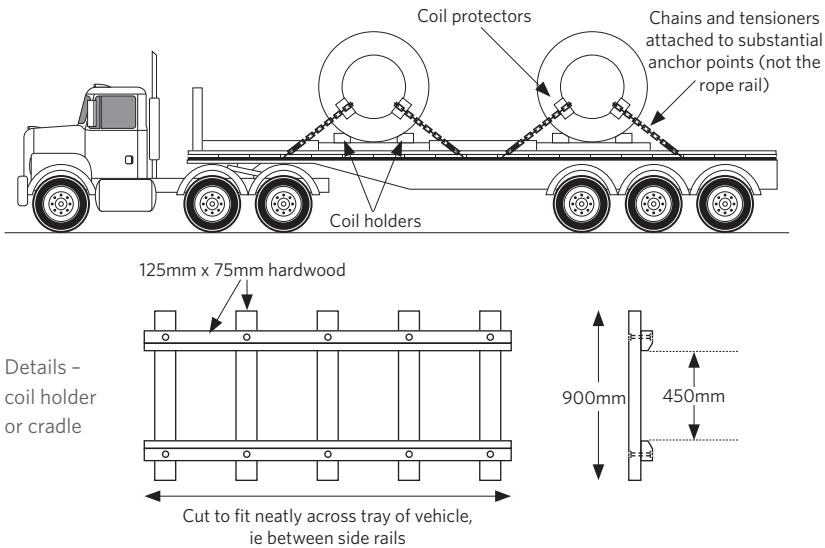
All coils of metal or wire should be blocked each side and the chain drawn through the centre of the front and rear coils to stop any movement forwards, backwards or sideways. This may also require the use of further binders as well as blocks and chains.

### *Coils: eye horizontal carried crosswise*

Whenever possible, coils should be transported on specially constructed vehicles.

A row of coils is one or more coils in a line across or along the vehicle. All coils in a row must be of approximately equal diameter.

Coils should not be loaded more than one layer high.



**Figure 64** Metal coils – eye horizontal, carried crosswise

Figure 64 shows a recommended restraint method for steel coils. The metal processor usually applies metal banks to the bare coils to provide both circumferential and end restraint.

It is important to cradle the coils in coil holders as illustrated. The coil holders must be positioned to distribute the load on the vehicle, to provide legal axle loads. They must fit neatly between the coaming rails to provide lateral restraint.

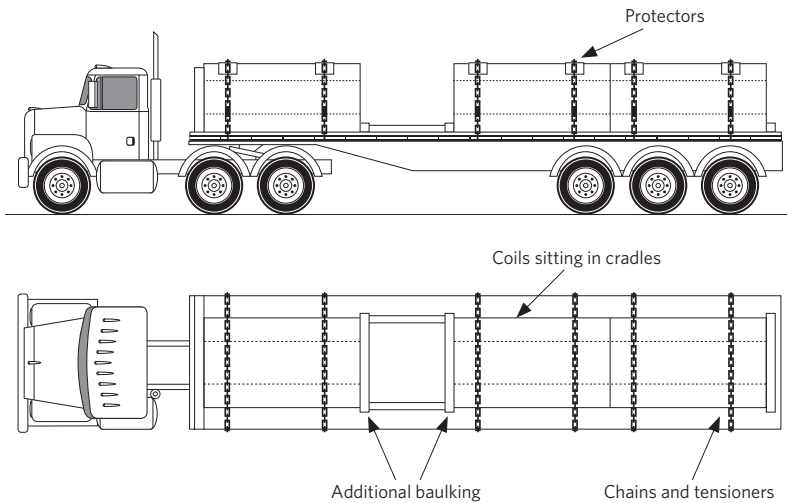
Fit a pair of chains and tensioners to each row of coils as shown in figure 65. Use coil protectors where indicated. Anchor chains to substantial anchor points, not to a rope rail.

### **Coils: eye horizontal carried lengthwise**

On the rare occasions when coils must be carried in rows aligned along the platform, the rows must be in contact along the centre of the platform and of equal length.

Cradles of the type shown in figure 64 should be used with the addition of 100mm × 100mm timber baulking bolted across both ends of the cradle hard against the end coils. The front baulking may be deleted if the leading coil is hard against a substantial bulk head.

Fit protectors between chains and load where necessary. Apply a minimum of two transverse chains and tensioners across each coil. Anchor chains to substantial anchor points, not to a rope rail (refer figure 65).



**Figure 65** Metal coils - eye horizontal, carried lengthwise

### **Coils: eye vertical**

Coils intended to be transported with eye vertical are usually mounted on and strapped to wooden pallets by the metal processors.

The coils and pallets must be positioned to distribute the load on the vehicle and to keep axle loads within legal limits. Restrain the coils with coil inserts, chains and tensioners as illustrated in figure 66.

Note also that the adjustable plate restraint shown in figure 63 may be effectively used as a coil insert. This would mean the use of additional protectors between chains and load were not necessary.

Pallets should be baulked or secured with a system of front and back restraint chains.

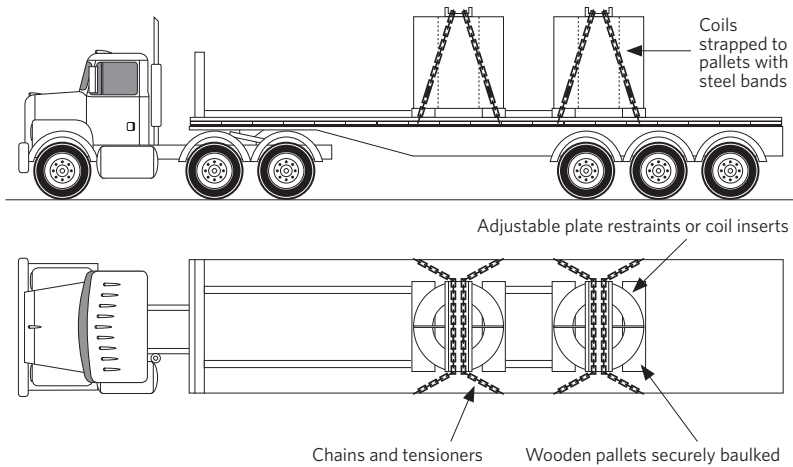


Figure 66 Metal coils, eye vertical

## METAL BARS OR BILLETS

This type of load poses particular problems as one bar can easily penetrate a headboard if it is allowed to move. It is essential that the vehicle is loaded in such a way that the complete load forms a unit and no bar or bars can slip out of the load.

### *Arrangement of the load on the platform*

The load must be stable without lashing. If lower layers are lashed to prevent spreading, this must be done before the next layer is put in place. Lashings must not support the weight of the upper layers. If the bars are laid along the platform, where possible, no bundle or pile should be bigger than a bundle or pile in front of it, and piles must be in contact or baulked to prevent forward motion.

### *Lashing*

Each pile must have sufficient cross lashings to comply with the conditions outlined on pages 8-13. If it is possible to baulk against sideways movement, this should be done. It may be necessary, if the load is not against the headboard, to

provide baulking to the height of the load at the front to prevent forward movement.

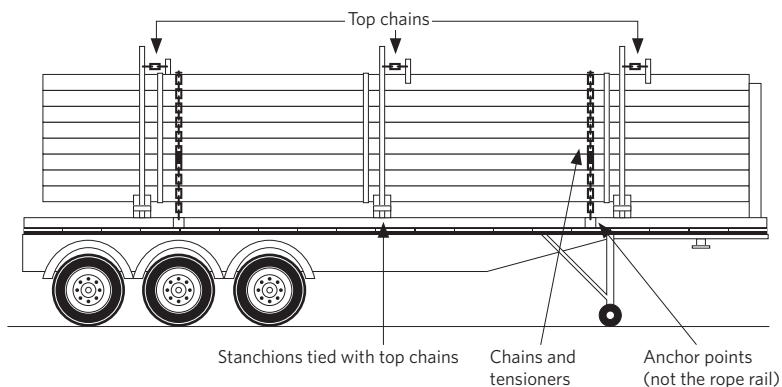


Figure 67 Steel bars, billets and pipes

## STRUCTURAL STEEL AND PIPES

Many of the problems associated with metal bars also apply to structural steel and pipes, and, in particular, to maintaining the load as a solid unit (for arrangement of the load on the platform see figure 67). The load should, whenever possible, be placed against the headboard or baulking, which should extend to the full height of the load. The load should be kept as low as possible, and smaller items placed on top. No layer should be bigger than the one beneath it.

The headboard or loading rack should be of sufficient height for driver protection (see pages 16-17).

### Lashing

The selection and use of lashing should be based on the principles set out on pages 18-25. Whenever possible, stanchions, either attached to the vehicle or to specially made bolsters, should be used to provide lateral restraint. The stanchions should extend to the height of the load and be fitted with top chains. If there are no stanchions, baulking should be used to prevent lateral movement. It is essential that the load be restrained in such a way that no single part of it is free to move in any direction independently of the rest. The use of dunnage should be avoided wherever possible, but if necessary, then it should comply with the requirements described on pages 8-13.

Figures 68 and 69 illustrate methods of securing prefabricated structural steel and rolled steel members. The prefabricated structural steel is secured by chains

spaced at 2 metre intervals attached to anchor points and fitted with load binders. The structural members are spaced above the vertical platform and from each other by 100mm x 50mm wooden spacer blocks placed at the position of the chains and load binders.

Rolled steel members are similarly restrained. Care must be taken in all cases to ensure that the front of the load is against a headboard or baulking to prevent forward movement. The load should be positioned to achieve the desired axle loading.

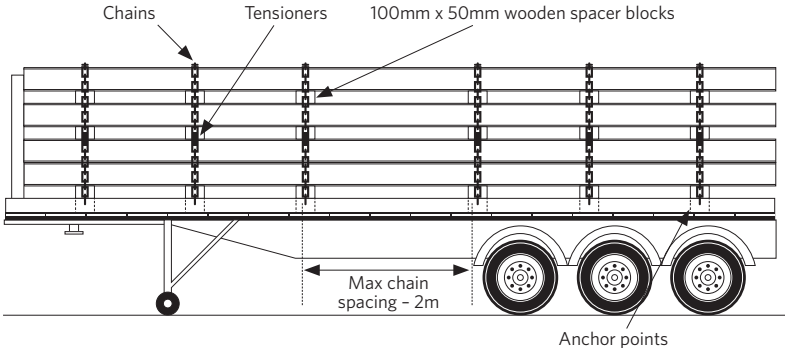


Figure 68 Prefabricated structural

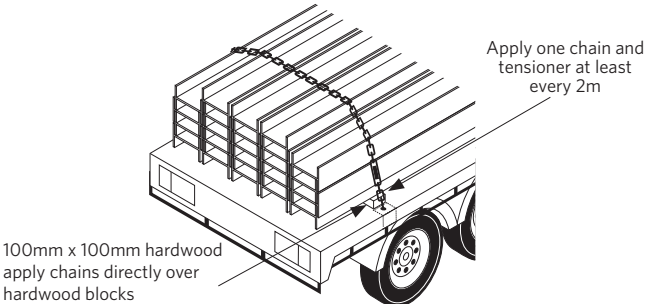


Figure 69 I-beams

**LARGE CASTINGS AND FABRICATED UNITS**

This type of load is usually carried in a custom-made cradle, which must be sufficiently strong to resist the forces which might be imposed on it.

It will often be impossible, for weight distribution reasons, to place this type of load against the headboard. Therefore, if no baulking is provided, all the restraint will have to come from the lashings, and a correspondingly greater number will be necessary.

The lashings must be arranged to prevent the load toppling as well as preventing movement relative to the vehicle. It will be necessary to lash over the top, or to points high on the load or cradle, even if baulking at deck level is used to provide the majority of the restraint.

## **WIRE COILS**

Wire coils carried on custom-designed vehicles according to the manufacturer's recommendation will be secure.

### *Load arrangement on vehicles*

When carrying coils on a flat platform vehicle you will, in general, need to place them in rows along the platform. It will be necessary to place the front coils against a vertical obstacle, usually the headboard, to prevent them falling over. All coils behind them must be kept as nearly vertical as possible. The rows of coils along the deck must be in contact with each other.

### *Lashing*

The coils must be baulked against sideways movement along the entire length of the load. The rearmost coils must also be baulked against rearward movement.

The lashings must prevent the coils from rocking backwards and forwards under braking and acceleration. Therefore, particular care must be taken to lash forwards from the rearmost coils. The lashings must comply with the basic criteria and precautions requirements as set out on pages 8-13.

## **SCRAP METAL**

Scrap metal can be of many forms and may or may not come into one of the categories itemised above. If it does, then the loading and lashing arrangements must be as outlined in the next section on loose bulk loads (pages 87-88).

Scrap metal may be carried in sided vehicles. The conditions which must be met are outlined in the next section. Care must be taken with loads of scrap to ensure that the load forms a complete unit, and all parts of it are secured to the standards outlined on pages 8-13.

It is preferable that scrap metal be placed in containers at the point of origin so that it can be handled by a crane from the ground to the truck. Care must be exercised to ensure that the loaded containers are suitably placed on the vehicle

so that at no time is the aggregate weight of the vehicle or any axle load limits exceeded.

## INGOTS

Ingots can be in many forms. Details of the loading and lashing arrangements are outlined in the pallet and general freight sections. Ingots can be carried in sided vehicles, or palletised on platform vehicles. Care must be taken to ensure that the load is safe and secure.

## Loose bulk loads

Loose bulk loads can generally be described as having a nature which does not readily lend itself to any form of packaging or containerisation, eg sand, aggregate, shingle, rubble, rubbish, asphalt and other similar materials.

Clearly, the loading and securing of such loads do not pose the many problems associated with general freight, but nevertheless they do have security problems peculiar to themselves.

## BASIC SAFETY PRINCIPLES

The maximum vehicle and axle weights must never be exceeded. Loose bulk loads being transported in a vehicle without a tarpaulin fitted should at no time reach higher than 100mm below any side of the vehicle. If the load is heaped to its own natural 'angle of repose', this could result in load shedding due to the vehicle's movement. Doors to bulk bins must be closed to avoid loose bulk loads from being blown out.

As these loads normally rely upon the vehicle body for restraint it becomes extremely important to ensure all body-to-chassis attachment points, eg 'U' bolts, hinge pins, hinge pin brackets, are always secure and that these and the body are in sound condition.

Loose bulk loads should be tarped, netted or sheeted as appropriate whenever there is a risk of load shedding due to wind action or movement (see figure 70). Body work should be kept in good condition in order to minimise the hazards during transportation. This applies particularly to badly fitting tail gates that permit gravel and stones to fall to the roadway.

Body height extensions (topper boards) should only be used where conditions and type of load permit. In these circumstances, their supports must be adequately fixed to the existing body. It is not considered adequate to rely upon the load within the parent body of the vehicle for support. Where necessary, tie-chains should be used transversely at the top of body extensions to prevent sideways spread.





**Figure 70** Securing loose bulk loads

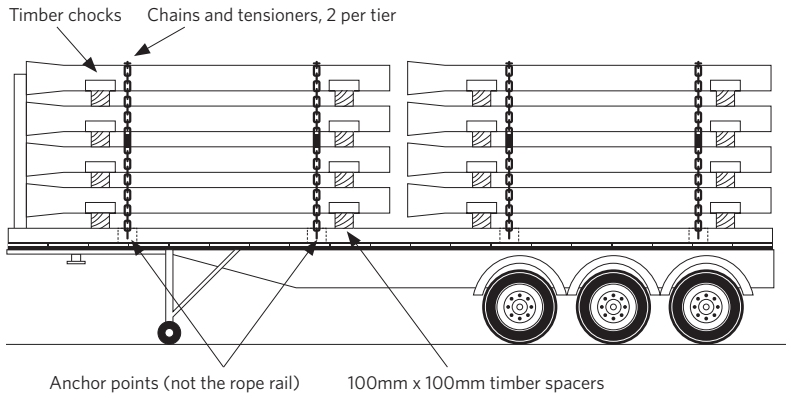
## Pipe loads

### METAL PIPE

Metal pipe is loaded lengthwise (see figure 71). Spigoted or flanged pipes should be stacked in tiers with 100mm × 100mm hardwood spacers between each layer of pipe. Lateral restraint should be provided by means of four chocks on top of the spacers between each layer. The leading end of the front tier of pipes should be located against the headboard.

At least two chains or webbings and tensioners should be applied to each tier with chains or webbings located over or adjacent to the timber spacers. They should be anchored to anchor points, not to an unsupported section of rope rail.

Parallel pipe spacer arrangements will depend on the length and diameter of the pipe. Also see pages 84–85.



**Figure 71** Typical spigoted pipe - loaded lengthwise

## ASBESTOS OR PLASTIC PIPE

Asbestos or plastic pipe is damage prone and is also loaded lengthwise (see figure 72). Pipe manufacturers usually prepare these pipes for transport by stacking them in tiers with timber spacers between layers and restrained with bands.

The leading ends of the front tier of pipes should be located against the headboard and the tiers restrained by at least two chains and tensioners to each tier. Alternatively, approved webbing lashings may be used.

It is important that lashings are located close to the timber spacers. Lashings should be kept in the same vertical plane, not over tensioned and anchored to anchor points. Unsupported section of rope rail must not be used.

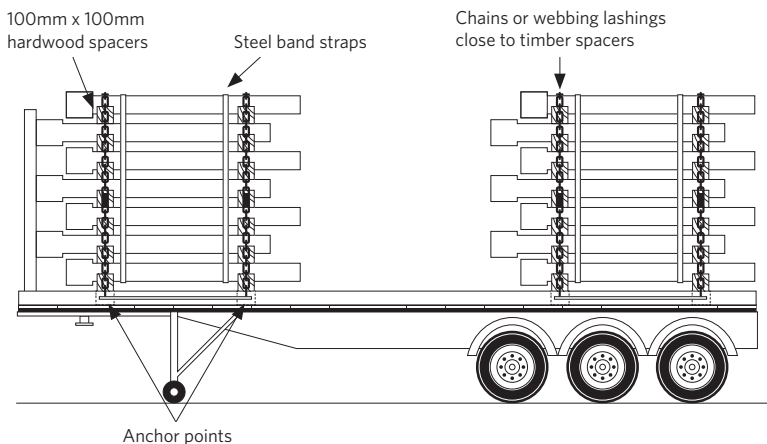


Figure 72 Asbestos pipe - loaded lengthwise

## CONCRETE PIPES

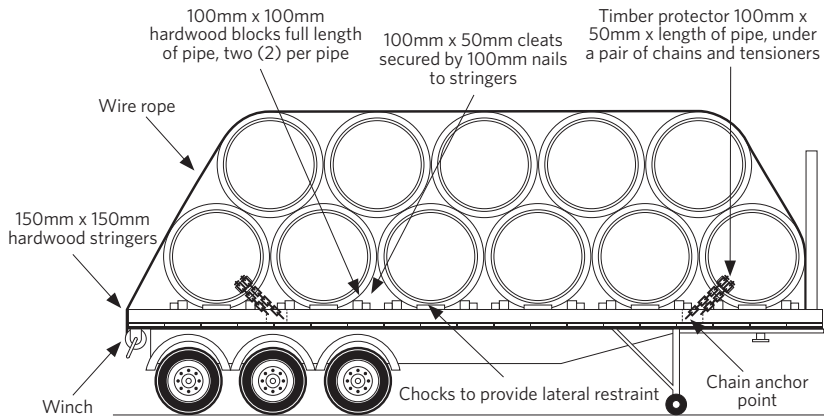
### Positioning of load

Pipes which can be loaded safely within the legal load width limit or overdimension general permit should be loaded across the vehicle (see figure 73). When the length of the pipes allow, it is preferred that they be loaded barrel to barrel.

Spigot and socket pipes, if only in one layer, should be loaded with the sockets at alternate ends. Where additional layers are loaded sockets should be at the opposite end to those in the immediately lower layer and the spigots should not project beyond the sockets.

To ensure security of the load, before loading commences, wedge-shaped timber should be firmly placed at the front end of the vehicle. The first pipe loaded should be pushed firmly against the wedge-shaped timber and chocked. Each pipe loaded thereafter should be pushed firmly against the previous pipe and progressively chocked.

Pipes longer than 2.5 metres should be loaded lengthwise along the vehicle. Where spigot and socket pipes are loaded the bottom layer should have the sockets at the same end. Where additional layers are loaded, sockets should be at the opposite end of those in the immediate lower layer and spigots should project beyond the spigots by those in the immediately lower layer.



**Figure 73** Concrete pipe – loaded crosswise

**Note:** Where socketed pipes are being loaded, at least two lines of timber, not less than 100mm × 100mm, should be placed along the floor of the vehicle. Where larger timbers are used, the largest dimension should be laid across the floor. The distance between the lines should be approximately, but not less than, half the length of the pipes loaded.

## **CARTAGE OF PIPE - EQUIPMENT**

### *Vehicle timbers (dunnage)*

Condition: All timbers used for supporting loads on vehicle trays must be properly shaped and free of protruding nails. Timbers made slippery by excess oil or grease must not be used.

Timber under pipe loads: To prevent movement and damage to concrete pipes all timber used in supporting them must be of sufficient width and height.

### *Chocks*

Chocks cut from good quality timber in clean condition must be provided in sufficient numbers for the pipes being loaded. All chocks which are split must be discarded.

### *Ropes and chains*

Each pipe-carrying vehicle must be provided with adequate good quality cordage, webbing, steel wire rope or tested chain for securing the load. Chains must not be knotted, welded or passed around sharp corners.

Minimum recommended sizes are:

- cordage 12mm diameter
- webbing 100mm
- steel wire rope 12mm diameter
- tested chain 8mm diameter of links.

Cordage that is frayed to any significant extent must not be used. Steel wire rope which is frayed, rusty or sharply bent must not be used. For more information see pages 18-25.

### ***Packing***

Sufficient durable packing material such as belting, second-hand rope or rope ends must be provided in order to protect pipes from damage. Such packing should be placed between the ends of all pipes in the bottom layer to protect the pipes coming into contact with each other. Packing material, preferably in one continuous length over the whole layer, should also be placed between each layer of pipes loaded. For short local trips under good conditions packing may be considered unnecessary.

## **SECURING METHODS ON TRAY OR PLATFORM VEHICLES**

### ***Chaining***

For cross-loaded pipes of diameter up to 1300mm, loads should be secured by two parallel chains front and back. Chains to be provided with load binders, turnbuckles or other suitable means of tightening.

For cross-loaded pipes of diameter greater than 1350mm, pipes should be secured by two parallel chains brought down to the vehicle platform between each pipe and evenly tensioned over each pipe.

### ***Roping***

For cross-loaded pipes of diameter greater than 450mm - where pipe loads are to be roped instead of chained at least two front and back ropes should be used. This should be supplemented by adequate random roping of individual pipes in each layer.

For cross-loaded pipes of diameter less than 450mm - pipes in each layer at random, roped through their barrels as in above, and secured by two chains running front and back.

Pipes loaded lengthwise - timbers should be wedged along the barrels of the outside pipes and the whole load held down securely by ropes passing over the pipes from one side of the vehicle to the other.

Layering of pipes – pipes should generally not be loaded in a greater number of layers than shown below:

NOMINAL PIPE DIAMETER	NUMBER OF LAYERS
150mm–225mm	6
300mm–375mm	4
450mm–600mm	3
675mm–1050mm	2
above 1050mm	1

Junctions may be placed on the top tier of pipes, and in all cases should be placed in a vertical position and roped to prevent rotation of the complete unit.

### *Use of tackle*

Slings or other tackle should be placed around the pipe or arranged so that the pipe when lifted is in a horizontal position. When chains are used, some padding should be provided between pipe and chain. Steel wire rope or chain slings must never be passed through the pipe for lashing or lifting.

Other tackle that will pass into or through the pipe must not touch the jointing surfaces of spigot or socket, should be rigid and extend far enough beyond the end of the pipe to ensure clearance of lifting wires or chains.

Pipes which have to be laid in one position are marked by a band of black or coloured paint, or by the word 'TOP' painted on them. Special care should be taken to lift these pipes with the 'TOP' uppermost.

Pipes with a lifting hole provided should be lifted by passing a looped single sling ('snotter') through the hole into the bore of the pipe and then around a baulk of timber which should be at least one quarter of the length of the pipe to be lifted and a cross-section not less than the following:

- For pipes up to 900mm – 100mm × 100mm.
- For pipes over 900mm – 150mm × 150mm.

## **Reels – paper, newsprint, plastics securing methods on tray or platform vehicles**

### **GENERAL**

The floor of the truck or trailer should be in good condition and for long-haul deliveries protective sheeting should be laid down prior to loading.

Where reels sit on raised coamings, levelling dunnage at least 100mm wide and of coaming height should be used alongside the coamings. Two strips should be placed adjacent to the longitudinal centre line of the loading space.

All long-distance transport of finished product should be effectively weather protected.

Chains, ropes, corner boards and chocks must be effectively refitted after delivering part loads. Core plugs, where used, should be replaced in reels as each reel is delivered.

It should be noted that in addition to the flat deck trucks and semi-trailers considered in this code, it is possible to transport reels and palletised or unitised products in van-type semi-trailers, provided forward, rearward and lateral restraints are provided within the confines of the van.

## **CARTAGE OF FINISHED REEL PRODUCTS - EQUIPMENT**

### *Chains, turnbuckles and core protectors for reels*

Each set should comprise equipment which meets the requirements outlined on pages 18–25.

Chains are used to fulfil two main functions:

- protection against rearward or forward loss of load
- maintaining the whole load in compression to produce extra frictional resistance against sideways movement of reels.

The tendency of chains (as primary restraints) to lose tension is related directly to movement of links that are in contact with the core protectors and the tie rails and coaming. Short links tend to move less and are preferred to long links.

Turnbuckles, where required, should be of the standard specified about chains on page 20.

Core protectors, when required, should be flanged in a manner to protect the core and reel ends (see figure 74).

All edges and parts of the core protectors that may come into contact with rope should be radiused and ground smooth.

### *Chocks for reels*

Wooden chocks of at least 100mm wide and 150mm high should be provided. Ropes are threaded through holes in the chocks in sets of two or four to assist in securing them to the side rails and also to reduce the risk of falling from the truck and causing a hazard to following traffic.

Chocks must not be left loose on the truck floor while the truck is in motion, because of the danger to following traffic.

### **Edge protectors – corner boards**

Where cores are plugged, corner boards should be used to restrain sideways movement of top reels. Boards should be 150mm × 40mm timber and about 2400mm in length. When used, the restraining lashings must have a combined rated strength at least equal to the weight of the load.

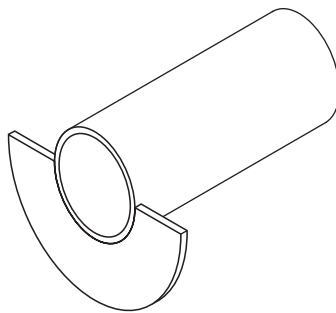
### **Reel bars**

For general assistance in manoeuvring of reels, only round pipe or bars whose outside diameter is no less than 32mm are acceptable. One end should be flattened and any sharp edges ground off. Bars must not be left loose on the truck floors when the truck is in motion, because of the danger to following traffic. A duralumin bar or other alloy bar of adequate strength is acceptable.

### **Ropes**

Enough ropes to meet all requirements for securing the load are required.

Each rope should be not less than 9 metres long. For some applications longer ropes may be required. See page 18 for the specification of rope.



**Figure 74** Core protector

## **CARTAGE OF FINISHED REEL PRODUCTS – SECURING METHODS**

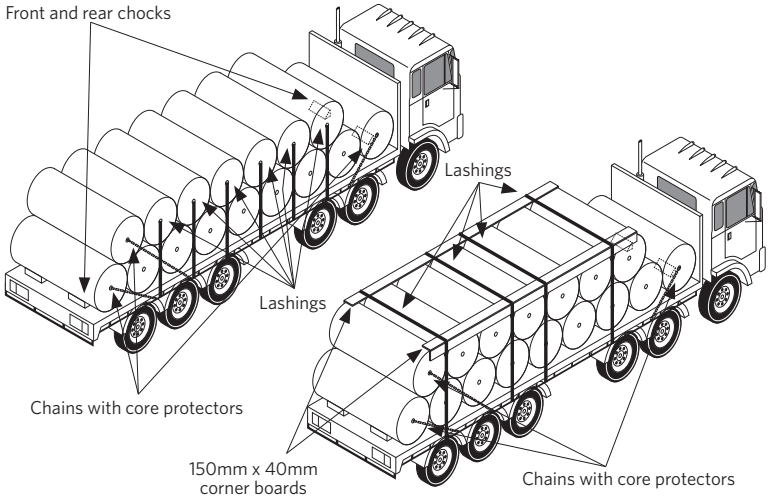
### **Reels stowed on the barrel**

Reels up to 1000mm diameter – should preferably be secured in unitised modules. However, where stowed loose, the securing principle applicable to larger reels should be observed.



Reels 1000mm to 1300mm diameter (including fully wrapped reels) – reels in this diameter range may be stowed one and two high on the barrel. Two large wooden chocks should be placed symmetrically behind each rear reel or reels and in front of each front reel except where permanent front chocks are provided. Secure all main chocks tightly by threading rope through the holes in the chocks and tying to the tie rails. After inserting core protectors in the outsides of the front and rear bottom reels, place chains through the cores of the rear and front bottom reels and tighten with turnbuckles diagonally to the side rails, taking care to keep them clear of reel ends during tightening. The chains should be angled at less than 45° to the horizontal.

Reels up to 500kg – fit core protectors to each reel in the top row and apply 12mm polypropylene ropes.



**Figure 75** Loading requirements for barrel stowed rolls 1,000mm diameter and over

Reels 500kg to 1000kg – fit core protectors and either apply chains to the top row, or ropes to each reel in both the top and bottom rows.

Reels 1000kg or more – fit core protectors to all reels in top row and apply chains to each of these reels.

Remember the combined rated strength of chains and ropes used must equal at least the total weight of the load.

Reels 1500mm to 1730mm diameter – the same securing methods applicable to 1000mm to 1300mm diameter reels apply but the reels should not be stowed two high.

Narrow width reels – reels whose width is less than half the diameter should not be barrel stowed more than one high. Otherwise use the same securing methods applicable to the corresponding diameter but wider reels.

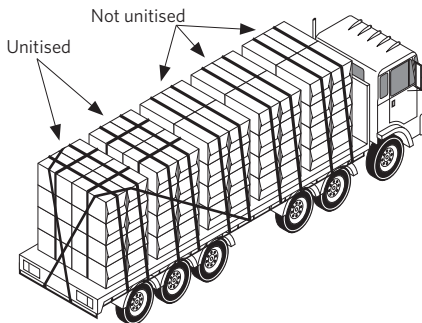
## **CARTAGE OF BALED PULP – SECURING METHODS**

### ***Woodpulp – not unitised with wire or strapping***

Subject to the characteristics and the bale formation, it may be necessary to restrict the loading to less than four high. Figure 76 illustrates this.

Each lateral row of bales, whether palletised or not, should be secured with one cross rope from side to side, and the rear of the load secured by a pair of ropes crossed diagonally from the rear thence over the load well forward to the side tie rails. Pulp must not overhang the rear of the vehicle.

The diagonal pair of ropes may be omitted when the vehicle is fitted with a rear load rack in position, provided the rear stack of pulp is located close to the rack and does not exceed the rack in height.



**Figure 76** Baled pulps

### ***Woodpulp – unitised with wire or strapping, up to four bales high***

Secure each unit with cross ropes from side to side with one rope per lateral row of bales. The rear of the load should be secured by a pair of ropes crossed diagonally from the rear, then over the load well forward to the side tie rails. Pulp must not hang over the rear of the vehicle. Refer to figure 76.

The diagonal pair of ropes may be omitted with unitised pulps when the vehicle is fitted with a rear load rack in position, provided the rear unit pulp is located close to the rack. Unitised pulp may exceed the rack in height.

# Carriage and towing of motor vehicles

## CAR CARRIERS

Vehicles used regularly for the carriage of motor cars over long distances are generally well equipped with specially designed wheel wells/chocks, anchor points, winches and other restraining devices, but operators carrying motor cars intermittently for short distances are tempted to rely on the force of gravity or on inadequate cordage lashed to the suspension members of the motor cars being carried.

## WHEEL CHOCKS

Where wheel chocks are used they should be secured to the tray or the special wheel tracks by 10mm pins or bolts capable of being locked to prevent dislodgement by vibration. Chocks should be firmly placed on each side of all vehicle wheels. Some chocks incorporate the securing winches, see below.

## ANCHOR POINTS

Anchor points on the carrier should be fixed securely to the metal members of the chassis and be capable of withstanding a force of at least 2 tonnes acting in any direction through which lashings or restraints may be attached. The number of anchor points on each side of the carrying vehicle should be related to the sum of the total number of axles of motor cars carried at a given time.

## WINCHES

It is now general practice to affix tensioning winches to car carrier trucks and trailers wherever the design of the truck or trailer permits. These comprise a winch and high tensile steel chain or 4mm wire rope with a hook at the attachment end of the chain or wire rope. If wire rope is used it is essential that the wire ropes are directed around pulleys.

The more elaborate winches are combined with wheel chocks and are fully adjustable up and down the length of the deck. This system ensures that there is pressure against the wheel and pulls the car down without bending the car body.

The number of winches used per car on the truck or trailer will vary from two, three to four. Should only two winches be affixed they must be capable, together with chocks, etc to restrain the car so that the 'g' force criteria outlined on pages 7-12 is met. Ideally, four winches should be supplied.

Most car manufacturers provide securing points (holes) in the chassis of their products for the attachment of chain hooks. These also vary from two, three to four sites.

Where securing points are not provided on the car, the chain or wire rope is wrapped around the axles at the front and rear ends of the car. On these occasions care must be taken to ensure that chains and wire ropes do not damage brake hoses or other components.

## **VEHICLE RESTRAINT**

Restraints must be attached to special underbody brackets, when fitted to the motor car. When special vehicle underbody brackets are not provided, lashing over the axle is acceptable. In this instance, care must be taken to ensure the freely sprung body cannot be damaged against adjacent fittings. Motor car manufacturers recommend that to avoid possible damage to the drive train of motor cars being carried, the parking brake should be firmly applied and manual and automatic gear boxes set at neutral.

Automatic gearboxes should never be set at the 'low', 'second', 'drive', or 'reverse' positions.

Front and rear lashing must be used in association with wheel chocks. At least two lashings should restrain each vehicle.

## **REGULATIONS**

The maximum legal weight limits and vehicle dimensions must not be exceeded. Particular attention should be given to loading height, especially when transporting light vans etc.

## **LOADING RAMPS, HYDRAULIC OPERATED DECKING, ETC**

Care should be taken to ensure that all loose loading ramps are safely secured. Hydraulic ramps and decks should be secured in the locked position.

## **FUEL TANKS**

Fuel tanks of motor cars being carried should contain only sufficient fuel for the motor car to be driven on and off the car carrier in the storage yards.

## **TOW TRUCKS**

### *Jib towing of damaged or disabled motor vehicles*

Several precautions should be taken to ensure that the vehicle being towed does not break away or become loose and to prevent further damage to the vehicle under tow.

A towing sling and spacer bars should always be used. Safety chains, to take the load off the winch and cable while the vehicle is under tow, are necessary.

Slings should be hooked to the lower suspension arms or, if the rear of the vehicle is lifted (towing it on its front wheels), hooks and chains should be attached to the rear of the axle. Wooden blocks, rubber cushions or fabric fenders should be used at splash pans, tail pipes, oil sumps and fuel tanks, to avoid damage to these components.

Do not hook on to the tie rods, steering linkages or other parts that could be damaged by unusual pressure. Do not hook over the top of an axle or suspension member because the hook could become unfastened during travel.

Make sure that spacer bars are retracted and locked before towing. Check that the car is in neutral gear and the parking brake released before towing.

### *Advantages and disadvantages of towing vehicles on their front wheels*

On rear wheel drive vehicles, the chief advantage is that the vehicle's transmission will not limit either towing speed or distances. This can be a significant advantage when towing trucks.

Practically all passenger cars with automatic transmissions present limitations during towing. Generally such cars towed on their rear wheels should not exceed a speed of 40km/h and a distance of 20km unless specific factory recommendations allow higher limits. The main disadvantage in front-wheel towing is the danger that would result if the front wheels failed to remain secured in the straight ahead position, allowing the disabled vehicle to swing. Steering wheel locks, specially designed for this purpose, are available in the trade.

## Flexible tanks

These guidelines apply to the transportation of fluid carrying tanks of the non-rigid type and are based on overseas tests and regulations as well as New Zealand tests. When empty these tanks are usually rolled up so that the deck of the vehicle can be used for other loads. Consultation with the statutory authorities is required if hazardous liquids are proposed to be carried in flexible tanks. Higher safety standards will be required.

Whereas most loads rely on partial rigidity of the load to prevent forward and sideways movement, this is not the case with these flexible tanks where all forward and sideways movement must be restrained by the lashings alone.

**Note:** Lashings refers to rope, chain synthetic webbing straps, etc. The lashings must therefore be of extra high standard.

The tanks are usually made of a fabric reinforced rubber and should have sufficient strength in fabric and seam joints to withstand dynamic surge loads up to 1 'g'. Reduction of surge can be achieved by ensuring that the tank is filled to the capacity as specified by the manufacturer. Any air is dispelled and the tank is tightly secured to the vehicle.

There are two methods by which the tanks can be transported - within a container, or on the flat deck of a truck or trailer.

### CARRIAGE WITHIN ISO TYPE CONTAINER

The container is to be designed to the standard specified by the International Organization for Standardisation (test recommendation R1496). This is the standard to which general ISO freight containers are designed.

Anchorage rings designed for a safe working load of 5000kg are to be installed within the container to the base frame at intervals of not greater than 1.5 metres along each side (refer to British Hovercraft Corporation specification BH/FT/FI/246 or BH/FT/FI330 for details of anchorage rings). The lashing must be synthetic webbing strap with a rated strength of at least 2000kg.

### CARRIAGE ON FLAT DECK TRUCK OR TRAILER

The width of the flexible tank when full and secured to the deck is not to exceed 2.5 metres.

The number of lashings to be applied is as follows:

WEIGHT OF TANK PLUS MAX LOAD KG	MINIMUM NO. OF LASHING
0-1999	3
2000-3999	4
4000-5999	5
6000-7999	6
8000-9999	7
10,000-11,999	8
12,000-13,999	9
14,000-15,999	10
16,000-17,999	11
18,000-19,999	12

The lashing is to consist of synthetic webbing strap with a rated strength of not less than 2000kg. Chain is not recommended because of abrasion problems. However, if used, a protective covering between the flexible tank and chain must be used.

There are two systems of arranging the lashings:

### **INDIVIDUAL STRAPS**

When these are used they should run from the anchor point at one side of the vehicle over and in a full circle around the tank, then down to an anchor point on the other side of the vehicle (refer figure 77). Because the liquid is inclined to affect the shape of the tank during deceleration, the lashings should be distributed somewhat more closely at the forward part of the tank (refer figure 78).

### **WEBBING ARRANGEMENTS**

Where a stitched net of synthetic fibre webbing is used, ropes or webbing straps may be used to complete the system of securing to the vehicle (refer figure 79). Chains may be used. However if they come into contact with the surface of the flexible tank a protective covering must be used.

Any ropes used in webbing arrangements must be of good quality and at least 16mm diameter.

Any chains used must be at least:

➤ Grade 30 mild steel 10mm diameter

OR

- Grade 40 high tensile steel 8mm diameter.

Any strainers, hooks or other fittings used in connection with lashings must be strong and fastened so that they will withstand a force of at least the same magnitude as the part of the lashing to which they are joined.

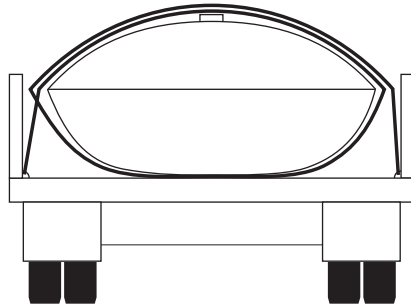


Figure 77

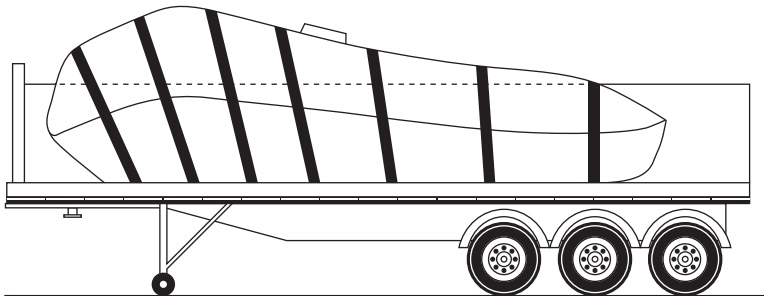


Figure 78



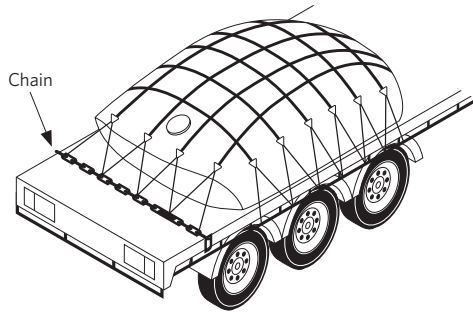


Figure 79

A headboard must be fitted to the truck and any trailer used for the carriage of flexible tanks.

Any side boards and tail boards fitted must reach at least 100mm above the highest point of the maximum width of the tank. In this case anchor points will have to be fitted on the deck of the vehicle within the side and tail boards (refer figure 80).

Two smaller tanks should be carried in preference to one large tank to further decrease surging. A chain may then be securely fastened between the tanks to the deck of the vehicle so that any longitudinal lashings may be secured to this chain (refer figure 79).

If the securing system is to retain the tank in an emergency situation, the hooks or tie-rails on the vehicle must be of a high standard. It must be realised that the combined weight on the hooks or tie-rail can be equivalent to half the total weight of the load in such a situation.

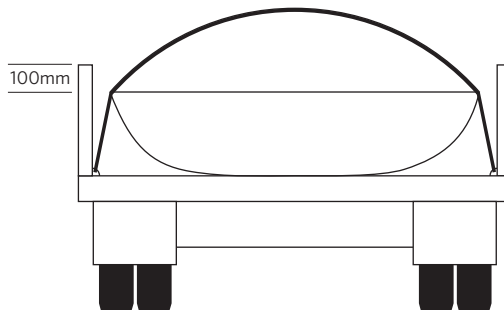


Figure 80

## Dangerous goods

Land Transport Rule: Dangerous Goods 2005 (the Dangerous Goods Rule) sets out requirements for safe transport of dangerous goods on land. This includes requirements for:

- packaging
- labelling and marking
- documents
- segregation
- placarding
- transport procedures
- training and driver licence endorsement
- responsibilities.

Factsheets that explain your responsibilities under the rule are available from the NZTA. Copies are also available at [www.nzta.govt.nz](http://www.nzta.govt.nz) under the resources and manuals section. The Dangerous Goods Rule can be bought from bookshops that sell legislation.

## Live loads

‘Live’ loads are those loads that can be expected to move when transported such as livestock, hanging meat and all liquids. Liquids include high viscosity sludges, molasses and tar.

Live loads can reduce vehicle cornering ability and cause rollover. If liquids are transported in partially filled tanks they should be baffled or have multiple compartments which are either essentially full or empty. If the rear compartment is full and the forward compartments empty, the loaded rear compartment will act as a pendulum (rearward amplification) and may pull the vehicle over.

Where loads, such as meat, are hung in a vehicle, they must be closely packed to minimise movement or otherwise be restrained.

Livestock is normally carried in purpose-built bodies or removable crates. Livestock should be loaded to minimise injury to individual animals and to prevent vehicle instability caused by the livestock moving during transport.

Where livestock is carried on light vehicles, crates must be used or the livestock directly restrained (tethered) to minimise movement.

Where livestock is carried in multiple deck crates, animals should not be transported in an upper deck until the lower levels are filled.

# Appendices

## Appendix A

### GLOSSARY OF INDUSTRY TERMS

**aggregate mass** – The maximum permissible laden mass of a particular vehicle.

**anchor points** – See load anchor points.

**baffles** – Barriers erected transversely and sometimes longitudinally in tanks used for transportation of fluids. Baffles are intended to limit surging of tank contents due to changes in vehicle acceleration.

**baulking** – Large timber at least 100mm × 100mm used to prevent longitudinal movement of the load under vehicle deceleration or acceleration, especially when the load cannot be placed against a headboard.

**bolster** – That part of a machine or mechanism which forms a hard support or base.

**blocks or blocking** – Suitable material used as baulking or packing against a load.

**cantling** – A support frame under a cylindrical object.

**cap tarp** – Tarpaulins fitted across the top of the load and general tarpaulins fitted to 'cap' the others.

**chocks** – Suitable blocks used primarily to restrain loads that could move during transit. Also known as cleats or scotches.

**claw** – A device incorporating prongs for grappling or holding.

**cleats** – See chocks.

**coaming** – A raised frame border on edge around the load platform of a vehicle.

**cribbing** – A reliable method of supporting loads by means of suitable packing. Material of uniform thickness is stacked in spaced pairs. Alternate layers of packing are placed at 90° to one another to form a stable column.

**crossbearer** – A support placed transversely across the loading platform.

**dunnage** – Packing placed between the base of the load and the surface of the vehicle's load platform to level and/or cushion the load. It may also be placed between parts of the load to keep them steady.

**edge protectors** – Material used to protect the exposed edges of relatively soft sheet and similar materials from the lashing used.

**flush deck** – A flat tray deck without coaming.

**gate** – Vertical frames used at the front, sides and rear of load carrying platform to contain the load. The front gate is also known as a loading rack or head board. It is important that the front rack be of adequate strength to ensure that any load shifting, as in cases of an accident or rapid deceleration, does not result in damage to the driver's cabin or any vehicle operating accessories.

**general tarp** – See tarpaulin.

**gross combination mass (GCM)** – The maximum of the sum (as specified by the manufacturer) of the laden mass of the vehicle plus the axle loads of any vehicle being towed as a semi-trailer or trailer. Can also refer to measured weigh bridge mass or the road regulation limit.

**gross vehicle mass (GVM)** – The maximum laden mass (as specified by the manufacturer) above which the motor vehicle should not be operated.

**headboard** – See gates.

**lashings** – Fastening devices, chains, cables, ropes or webbing used to restrain loads.

**lifts** – Dressed timber or steel which has been stacked in layers.

**load anchor point** – Robust devices to facilitate attachment of one or more lashings to the main frame or chassis of a vehicle to restrain the load.

**load binder** – A device fitted to each chain or lashing used to tighten (tension) the restraint. The binder manufacturer's recommendations should be applied. Frequently over centre locking action is incorporated.

**load capacity** – The maximum load which may be carried in or on any motor vehicle upon any road. It is equal to GVM less tare mass.

**loading rack** – See gate.

**loading stake, peg or pin** – A metal fixture used for load control when set in pockets.

**outrigger** – A horizontal beam, spar or framework projecting from the loading platform of the vehicle. Some may be retracted and/or extended.

**pallet** – A portable platform or tray onto which loads are placed to facilitate mechanical handling.

**pockets** – Female housings fixed to the vehicle to locate gates, stakes or loading pegs.

**rave** – A rail or framework (permanent or removable) added to the sides of the loading platform to increase load capacity.

**rope hooks** – Attachments fixed to the surrounds of the load platform to facilitate securing of tarpaulin hold down ropes. Rope hooks are not load anchorage points; they do not have sufficient strength and must not be used to restrain loads.

**rope rail** – A rail which skirts the perimeter of the load platform below the coaming. Used to secure rope. Support points may be used for limited load restraint.

**round timber** – Felled trees, logs.

**shackle** – A metal coupling link closed by a bolt. Used for connecting chains to anchor points. The two principal shapes are 'D' and 'bow'.

**sheet** – See tarpaulin.

**shooks** – Broken down cases.

**shoring bar** – Metal or wooden load-carrying beam or fabricated truss section used to restrain or transmit a load from one frame, column, post, wall or bearing point to another. May be adjustable. Also known as shoring pole.

**sling** – A length of hemp-core rope or steel-wire rope with eyes formed by splicing at each end. Used to hoist or restrain loads. May be webbing.

**snotter** – See strop.

**spreader** – A transverse spar or frame used to support tarpaulins or for load control; see strut.

**spigot** – The male cylindrical end of a fitting which mates with a hole in another component thereby forming a joint (connection, support).

**strop** – A cradle made from suitable flexible material to facilitate hoisting of a pulley or similar loads. Also known as a snotter.

**strut** – A rigid support intended to bear loads in the direction of its length.

**tarpaulin (tarp)** – A waterproof sheet used to cover and protect goods from the weather.

**thimble** – A metal liner, usually pear-shaped and concave on the outside that is fitted into the eye of a rope to prevent chafing and to distribute the load.

**tie-down fittings** – An anchor point and fitting designed to facilitate fastening or restraining of a load.

**transverse beam (spar)** – A beam aligned across the minor span of an area rather than longitudinally along the major span.

**turnbuckle** - A type of coupling fitted between the ends of a lashing or between two lashings. Used primarily for adjusting or regulating the tension in lashings. It consists of a loop or sleeve with a screw thread on one end and a swivel at the other. Alternatively it has an internal screw thread at each end.

**twistlock** - A locking device designed to fasten containers to the vehicle on which they are being transported.

**twitches** - See load binder.

**wedge** - A piece of wood or metal, thick at one end and tapering to a thin edge at the other.

**winch** - Load control device that uses chains, ropes or webbing lashings.

# Appendix B

## CHAIN

### *Current standards*

- AS/NZS 4344.
- BS 4942 is six parts and titled: *Short link chain for lifting purposes*. This standard incorporates the following ISO standards – 1834, 1835, 1836, 3075, 3076, 3077.

The requirements of the above standards are essentially the same. In the following any significant difference in the contents of these standards will be stated; minor differences will be ignored.

The standards detail the minimum requirements for compliance, eg details of such as: manufacture dimensions marking material composition testing procedure mechanical properties certification.

### *Identification*

The features by which a chain may be identified are:

- its dimensions, ie size
- marking.

### **CHAIN SIZE**

The size of the chain refers to the nominal diameter of the material from which the link is made. The standards specify the maximum and minimum limits of the diameter of the material for every nominal chain size. These limits on material size are roughly  $\pm 5$  percent of the normal diameter.

To obtain the chain size, the material from which the link is made should be measured:

- either on the straight portion of the unwelded leg of the link
- or, if both legs of the link are welded, on the straight portion of the link adjacent to the weld
- in two positions at right angles in the same plane; the dimension is to be taken as the mean of the two measurements.

### **MARKING**

#### ***Grade marking***

The letters L, M, P, S and T are used to designate the strength grade of the chain. The letter designating the particular strength grade must be stamped or embossed on either every twentieth link or every 1 metre of chain, whichever is the lesser.

The marking must not:

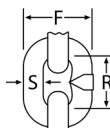
- coincide with a weld
- be situated where the material is displaced by the weld
- be situated on the extrados (the extrados is the outer curved surface of the link).

### Identification marking

The following marks must be legibly and permanently displayed either on the links of each manufactured chain length or on metal tabs which are permanently attached to each end of each manufactured chain length:

- the manufacturer's name or trademark
- the lot number or other reference mark which indicates the order against which the chain was supplied.



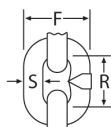
	Chain size S mm	Min break strength kg	R mm	F mm	Finish either
	7.3	6,700	23.8	25.9	Gold
	8.0	7,500	23.8	27.0	Black/Gold
	10.0	12,000	29.8	34.3	Black/Gold
	*13/12.5	18,000	38.8	44.6	Black

PWB Chain markings & specifications – pre 1997



Close-up of marking detail

4344-⊕-0

	Chain size S mm	Min break strength kg	R mm	F mm	Finish either	⊕ Box indicates marking of
	7.3	6,000	23.8	25.9	Gold	3
	8.0	8,000	23.8	27.0	Black/Gold	4
	10.0	12,000	29.6	34.3	Black/Gold	6
	*13/12.5	18,000	38.0	42.0	Black/Gold	9

\*Indicates link diameter 12.5mm. Use of grab hooks or systems incorporating grab hooks reduces the lashing capacity by 25%.

PWB AS/NZS4344:1995 Chain markings & specifications – 97/98 onwards

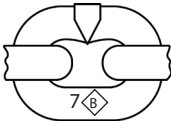


The chain tables are reprinted by permission from the Lifting Equipment Engineers New Zealand Inc.

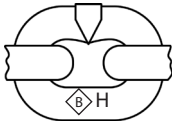
**Chain strength**

**Note:** With respect to the table on page 114:

- Tonne = kN 9.81
- AS/NZS 4344 lists the preferred chain sizes in mm as follows: 6, 7, 7.3, 8, 10 & 13
- The table does not give the breaking strengths of chains larger than 16mm; these larger sizes are considered too clumsy for normal load securing purposes.



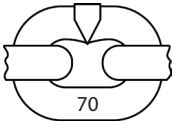
Freight 70



Hi TEN

Chain size S mm	Min break strength kg	R mm	F mm	Finish either
8.0	8,000	24.0	27.8	Black/Gold
10.0	10,500	29.5	34.0	Black/Gold
*13/12.5	16,500	37.5	41.8	Black/Gold

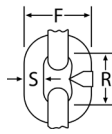
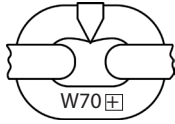
Bradlink chain markings & specifications



Chain size S mm	Min break strength kg	R mm	F mm	Finish
8.0	8,000	25.0	28	Gold
10.0	10,500	30.0	34	Gold
*13/12.5	16,500	38.4	44	Gold

\*Indicates link diameter 12.5 mm. Use of grab hooks or systems incorporating grab hooks reduces the lashing capacity by 25%.

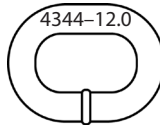
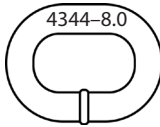
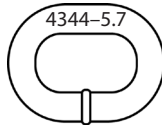
Serafini chain markings & specifications



Chain size S mm	Min break strength kg	R mm	F mm	Finish	Box indicates marking of
7.0	5,300	24.0	26.0	Gold	A
8.5	8,300	25.5	29.5	Gold	C
10.0	11,700	29.6	34.5	Gold	F
*13/12.5	18,000	39.0	45.8	Gold	E

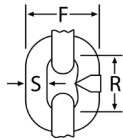
### Wiensel chain markings & specifications

AS/NZS  
4344:1995



Front

Back



Chain size S mm	Min break strength kg	R mm	F mm	Finish
7.0	5,700	21.6	24.4	Gold
8.0	8,000	23.4	27.9	Gold
10.0	12,000	29.5	34.5	Gold

\*Indicates link diameter 12.5 mm. Use of grab hooks or systems incorporating grab hooks reduces the lashing capacity by 25%.

### Yoke grade 70 transport chain markings & specifications

## Grade 80 & 100 chain (designed for lifting)

Used for specialist heavy transport applications

Size (mm)		Min break load (kg)
7.0	Grade 80	6,000
7.1	Grade 80	6,400
8.0	Grade 80	8,000
8.0	Grade 100	10,000
10.0	Grade 80	12,800
10.0	Grade 100	16,000
12.5	Grade 100	25,000
13.0	Grade 80	21,600
16.0	Grade 80	32,000

Grade 80 & 100 chain (designed for lifting). Used for specialist heavy transport applications

### Grade 80 & 100 chain markings

KUPLEX	T, KUPLEX, A8A
PWB	HA800, G80, G800
SERAFINI	T8
GUNNEBO	G8
BRADLINK	T(80)
WEISSENFELS	T(80)
WILLIAM HACKETT	HA 8
KITO (Grade 100)	KITO

Chain links vary in size subject to manufacturer.  
Contact supplier for verification.

Grade 80 & 100 chain markings

**Minimum breaking strength and elongation of chain to BS 4942**  
Grade (min elongation %)

Nominal size	L(20)		M(20)		P(17)		S(17)		T(17)	
	kN	Tonne	kN	Tonne	kN	Tonne	kN	Tonne	kN	Tonne
5mm	12.4	1.3	15.8	1.6	19.7	2.0	24.8	2.5	31.5	3.2
7/32 inch	15.3	1.6	19.4	2.0	24.3	2.5	30.6	3.1	38.8	4.0
6mm	19.7	2.0	25.0	2.5	31.4	3.2	39.3	4.0	49.9	5.1
7mm	25.0	2.5	31.7	3.2	39.6	4.0	49.9	5.1	63.4	6.46
9/32 inch	25.3	2.6	32.1	3.3	40.1	4.1	50.6	5.2	64.2	6.54
8mm	31.7	3.2	40.3	4.1	50.3	5.1	63.4	6.5	80.5	8.2
9mm	40.1	4.0	50.9	5.1	63.7	6.5	80.2	8.2	102.0	10.4
3/8 inch	44.9	4.6	57.1	5.8	71.3	7.3	89.8	9.2	115.0	11.7
10mm	49.5	5.0	62.9	6.4	78.6	8.0	99.0	10.1	126.0	12.8
11mm	62.1	6.3	78.9	8.0	98.6	10.1	126.0	12.8	158.0	16.1
12mm	78.5	8.0	98.2	10.0	126.0	12.8	157.0	16.0	197.0	20.1
1/2 inch	79.9	8.1	102.0	10.4	127.0	12.9	160.0	16.3	203.0	20.7
13mm	83.7	8.5	107.0	10.9	133.0	13.6	168.0	17.1	213.0	21.7
14mm	98.1	10.0	126.0	12.8	157.0	16.0	197.0	20.1	248.0	25.3
5/8 inch	125.0	12.7	159.0	16.2	198.0	20.2	250.0	25.5	317.0	32.3
16mm	127.0	12.9	161.0	16.4	202.0	20.6	254.0	25.9	322.0	32.8

Minimum breaking strength and elongation of chain to BS 4942

# Appendix C

## DETERMINATION OF LOAD SECURITY BY CALCULATION OR BY EXPERIMENTATION

### *Theoretical method*

The following simplified equation may be used to calculate, with satisfactory accuracy, the forces involved in securing rigid, non-rolling items such as cases, parcels, timber, etc. For a load consisting of a large number of separate items (bulk goods, rolling goods, etc) specially selected methods of calculation must be applied.

$$P = Qa - (10Q + S) \mu$$

Where

Q = the mass of the load (kg).

P = force which acts on the restraint equipment such as headboards, side post, etc (Newtons, N).

a = design acceleration level (m/s<sup>2</sup>). In the forward direction a = 10m/s<sup>2</sup> approximately, in the rearward and sideways direction a = 5m/s<sup>2</sup> approximately.

S = the sum of the tensile forces exerted by the vertical parts of the lashings (Newtons, N).

$\mu$  = friction coefficient for the contact surface between the load and its support. It may be assumed for these calculations that the coefficient of friction is 0.2. If a higher value is used, it must be justified by evidence, for example, a result obtained in a practical experiment.

### *Experimental methods*

#### **DETERMINATION OF FRICTION COEFFICIENT**

One method is to let the load unit while resting on its support be subjected to a horizontally acting force. The magnitude of the force F is measured at the moment when the load begins to slide on the support. The friction coefficient may then be calculated from the following relationship:

$$\mu = \frac{F}{10Q} \text{ (refer previous page for definition of symbols)}$$

Another method is to incline the load and its support on a progressively increasing angle until the load begins to slide on the support. The angle of

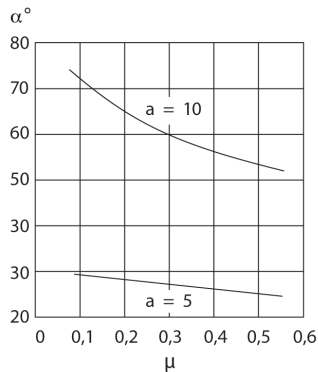
inclination,  $\alpha$ , is observed at the moment the load begins to slide. The friction coefficient can then be calculated from the relationship:

$$\mu = \tan \alpha$$

When experiments are carried out using this method, special measures must be taken to prevent loads with a high centre of gravity from tipping over during the trial.

### DETERMINATION OF THE EFFICIENCY OF LOAD FASTENING METHODS

While the load is resting on its support and fastened in a manner which is the subject of the test, the plane of the support is inclined on a progressively increasing angle, thereby stressing the load fastening devices. For the load fastening method to be considered to meet the requirements it must be capable of holding the load in position at the angle of inclination shown in the diagram at the design acceleration in question. The magnitude of the angle of inclination depends not only on the acceleration, but also on the friction coefficient,  $\mu$ , the value of which must therefore be determined first.



# Index

- **A**
  - adaptor frames 27
  - anchor points 15, 28, 49-50, 98, 106
- **B**
  - baulking 10, 106
  - bricks (see loading methods)
  - boxes/cartons (see loading methods)
- **C**
  - car carriers 98
  - cargo (see symbols)
  - cartons/boxes (see loading methods)
  - chains 20-22, 75-77, 110-115
  - clamps 19-20
  - coils (see steel products)
  - construction equipment 47-59
  - containers (types of) 30-31
  - cordage (see ropes)
- **D**
  - dragline excavator 58-59
  - drums (see loading methods)
  - dunnage 10, 106
- **F**
  - flexible tanks 101-104
  - forces 14
  - forklift truck 55
  - friction 5, 7, 10, 14, 116-117
  - fuel tanks 99
- **G**
  - gas cylinders (see loading methods)
  - general freight 35-46
  - glass (see loading methods)
  - glossary of industry terms 106-109
- **H**
  - hazards 51-59
  - headboards and racks 16-17

hydraulic excavator	53
hydraulic operated decking	99
<b>➤ I</b>	
ingots	87
<b>➤ K</b>	
knots	24-25
<b>➤ L</b>	
lashings	9, 11, 23, 78, 83-84, 84-85, 86, 99, 101-104
live loads	105
load securing equipment	18-25, 37-40, 63-66
load security – calculation/experimentation	116-117
loading methods	40-46
loading ramps	99
loads	
arrangement/distribution	11-13, 29-30, 36-37, 48-49, 78, 83
height	13
load restraint	8-11, 14-15, 37-40, 51-59, 60-62
logs (see timber loads)	
loose bulk loads	87-88
<b>➤ M</b>	
metal bars or billets	83-84
metal plate (see steel products)	
metal sheets (see steel products)	
mixed loads (see loading methods)	
<b>➤ P</b>	
pallets	32-34
paper (see reels)	
pipe loads	88-93
pneumatic tyred vehicles	56-57, 59
powergrader	54
<b>➤ R</b>	
rated strength	10-11
reels	93-97
restraining devices (see also lashings)	47-48, 50-51, 78
restraining methods (see securing methods)	
restraint equipment (see load securing equipment)	
rolls (see loading methods)	
rope	18-19
rubber tyred crane	51-52



➤ <b>S</b>	
sacks (see loading methods)	
safety	7, 32-33, 47-48
sawn timber (see timber loads)	
scrap metal	86-87
securing methods	51-59, 81-83, 92-93, 95-97, 97
specifications	
containers	26-30
headboards, loading racks	16-17
rope cordage	18-19
side and centre posts	17
side and rear gates	17
steel drums	33-34, 40-43
steel products	78-87
steel wheeled roller	57
steel wire rope	20
symbols (see general freight)	
➤ <b>T</b>	
tarpaulins	11, 38-40
timber loads	60-77
timber stacking and packeting	66-77
tow trucks	100
towing	98-100
tractor dozer	52-53
➤ <b>V</b>	
vehicle requirements (timber)	62-63
vehicle restraint	99
➤ <b>W</b>	
webbing and strapping	23-24
wheel chocks	98
winch	98-99
wire coils	86
wool (see loading methods)	